



American National Standard Methods of Measurement of the Electromagnetic and Operational Compatibility of Unlicensed Personal Communications Services (UPCS) Devices

Accredited by the American National Standards Institute

Sponsored by the
Accredited Standards Committee on Electromagnetic Compatibility, **C63™**

C63.17

IEEE
3 Park Avenue
New York, NY 10016-5997, USA
15 January 2007

ANSI C63.17-2006
(Revision of
ANSI C63.17-1998)

American National Standard Methods of Measurement of the Electromagnetic and Operational Compatibility of Unlicensed Personal Communications Services (UPCS) Devices

Accredited Standards Committee on Electromagnetic Compatibility, C63™

accredited by the

American National Standards Institute

Secretariat

Institute of Electrical and Electronic Engineers, Inc.

Approved 28 June 2006

American National Standards Institute

Abstract: Specific test procedures are established for verifying the compliance of unlicensed personal communications services (UPCS) devices with applicable regulatory requirements regarding radio-frequency emission levels and spectrum access procedures.

Keywords: etiquette, personal communications, RF emissions, spectrum access, unlicensed devices, UPCS

The Institute of Electrical and Electronics Engineers, Inc.
3 Park Avenue, New York, NY 10016-5997, USA

Copyright © 2007 by the Institute of Electrical and Electronics Engineers, Inc.
All rights reserved. Published 15 January 2007. Printed in the United States of America.

C63 is a trademark of the Accredited Standards Committee on Electromagnetic Compatibility.

PXI is a trademark of PXI Systems Alliance, Incorporated.

LabVIEW is a trademark of National Instruments, Incorporated.

Print: ISBN 0-7381-5021-5 SH95567
PDF: ISBN 0-7381-5022-3 SS95567

No part of this publication may be reproduced in any form, in an electronic retrieval system or otherwise, without the prior written permission of the publisher.

American National Standard

An American National Standard implies a consensus of those substantially concerned with its scope and provisions. An American National Standard is intended as a guide to aid the manufacturer, the consumer, and the general public. The existence of an American National Standard does not in any respect preclude anyone, whether he has approved the standard or not, from manufacturing, marketing, purchasing, or using products, processes, or procedures not conforming to the standard. American National Standards are subject to periodic review and users are cautioned to obtain the latest editions.

CAUTION NOTICE: This American National Standard may be revised or withdrawn at any time. The procedures of the American National Standards Institute require that action be taken to reaffirm, revise, or withdraw this standard no later than five years from the date of publication. Purchasers of American National Standards may receive current information on all standards by calling or writing the American National Standards Institute.

Authorization to photocopy portions of any individual standard for internal or personal use is granted by the Institute of Electrical and Electronics Engineers, Inc., provided that the appropriate fee is paid to Copyright Clearance Center. To arrange for payment of licensing fee, please contact Copyright Clearance Center, Customer Service, 222 Rosewood Drive, Danvers, MA 01923 USA; (978) 750-8400. Permission to photocopy portions of any individual standard for educational classroom use can also be obtained through the Copyright Clearance Center.

Introduction

This introduction is not part of ANSI C63.17-2006, American National Standard Methods of Measurement of the Electromagnetic and Operational Compatibility of Unlicensed Personal Communications Services (UPCS) Devices.

In November 1993, the Federal Communications Commission (FCC) invited ANSI C63 “to consider development of standard measurement procedures to support” proposed new provisions to Part 15 of Volume 47 of the Code of Federal Regulations (47CFR15)^a for unlicensed personal communications services (UPCS) devices. At its December 1993 meeting, ANSI C63 established a subcommittee (SC 7) to attempt to develop such standards in cooperation with representatives of the Wireless Information Networks Forum (WINForum) and other interested parties. The standard ANSI C63.17-1998 was the result of the efforts of SC 7.

In the fall of 2004, the FCC revised provisions of 47CFR15 governing the 1920 MHz to 1930 MHz UPCS band. A working group was formed under the aegis of SC 7 to rewrite ANSI C63.17-1998 to reflect the changes in 47CFR15. This revised standard is, again, the result of the efforts of SC 7.

Notice to users

Errata

Errata, if any, for this and all other standards can be accessed at the following URL: <http://standards.ieee.org/reading/ieee/updates/errata/index.html>. Users are encouraged to check this URL for errata periodically.

Interpretations

Current interpretations can be accessed at the following URL: <http://standards.ieee.org/reading/ieee/interp/index.html>. Notice to users

Patents

Attention is called to the possibility that implementation of this standard may require use of subject matter covered by patent rights. By publication of this standard, no position is taken with respect to the existence or validity of any patent rights in connection therewith. The IEEE shall not be responsible for identifying patents or patent applications for which a license may be required to implement an IEEE standard or for conducting inquiries into the legal validity or scope of those patents that are brought to its attention.

^a For information on references, see Clause 2.

Participants

At the time this standard was published, the Accredited Standards Committee on Electromagnetic Compatibility, C63, had the following membership:

Donald N. Heirman, Chair

Dan Hoolihan, Vice Chair

Robert L. Pritchard, Secretary

<i>Organization Represented</i>	<i>Name of Representative</i>
Alliance for Telecom Industry Solutions (ATIS).....	Chrys Chrysanthou James Turner (<i>Alt.</i>)
American Council of Independent Laboratories (ACIL)	Michael F. Violette William Stumpf (<i>Alt.</i>)
American Radio Relay League (ARRL)	Edward F. Hare Dennis Bodson (<i>Alt.</i>)
Cisco Systems	Werner Schaefer
Curtis-Straus LLC.....	Jon Curtis Jonathan Stewart (<i>Alt.</i>)
Dell Inc.	Richard Worley
ETS-Lindgren	Michael Foegelle Zhong Chen (<i>Alt.</i>)
Federal Communications Commission (FCC).....	William Hurst
Food and Drug Administration (FDA).....	Jon P. Casamento Jeffrey L. Silberberg (<i>Alt.</i>)
Hewlett-Packard Company	Kenneth Hall Colin Brench (<i>Alt.</i>)
Information Technology Industry Council (ITIC)	John Hirvela Joshua Rosenberg (<i>Alt.</i>)
Institute of Electrical and Electronics Engineers, Inc. (IEEE)	Donald N. Heirman
IEEE-EMCS	H. Stephen Berger Donald Sweeney (<i>Alt.</i>)
Lucent Technologies.....	Dheena Moongilan
National Institute of Standards and Technology.....	Dennis Camell
Society of Automotive Engineers (SAE).....	Poul Andersen Gary Fenical (<i>Alt.</i>)
Sony Ericsson Mobile Communications.....	Gerard Hayes Steve Coston (<i>Alt.</i>)
TUV-America, Inc.	David Zimmerman Joel Schneider (<i>Alt.</i>)
Underwriters Laboratories	Michael Windler Robert Delisi (<i>Alt.</i>)
U.S. Department of Defense—Joint Spectrum Center.....	Marcus Shellman Joseph Snyder (<i>Alt.</i>)
U.S. Department of the Navy—SPAWAR	David Southworth
Individual Members.....	Robert Hofmann Daniel Hoolihan John Lichtig Ralph M. Showers
Members Emeritus.....	Warren Kesselman Herbert Mertel Norman Violette

At the time this standard was completed, the C63 Subcommittee 7 Working Group had the following membership:

H. Stephen Berger, *Chair*

Dag Åkerberg, *Vice Chair*

Steve Cahill, *Technical Editor*

William Brasier

Greg Czumak
Joseph Dichoso

William Hurst

Contents

1. Overview	1
1.1 Scope	1
1.2 Applications.....	1
1.3 Roadmap to the document	2
2. Normative references.....	2
3. Definitions, symbols, acronyms, and abbreviations	3
3.1 Definitions	3
3.2 Symbols	5
3.3 Acronyms and abbreviations	6
4. Radiated and conducted emissions test methodology.....	6
4.1 Test facilities and equipment.....	7
4.2 Test configurations and setup	8
4.3 Transmitted power and monitoring threshold limits.....	9
4.4 Limits for radiated and conducted tests	11
4.5 Conducted measurements of products with identical collocated transmitting and monitoring antennas	11
4.6 Conducted measurements of products with collocated transmitting and monitoring antennas of different types.....	11
4.7 Conducted measurements of products with arbitrarily placed transmitting and monitoring antennas	12
4.8 Radiated measurements of products with identical collocated transmitting and monitoring antennas	12
4.9 Radiated measurements of products with collocated transmitting and monitoring antennas of different types.....	13
4.10 Radiated measurements of products with arbitrarily placed transmitting and monitoring antennas	13
4.11 Manufacturer’s declarations and descriptions.....	14
5. Measurement instrumentation	14
6. RF measurements	15
6.1 Emissions tests.....	15
6.2 Frequency and time stability.....	19
7. Monitoring tests.....	22
7.1 Introduction	22
7.2 Calibration of levels.....	25
7.3 Deferral thresholds and channel selection	26
7.4 Threshold monitoring bandwidth.....	29
7.5 Reaction time and monitoring interval	30

8. Time and spectrum window access procedure	31
8.1 Timing for EUTs using control and signaling channel-type transmissions	32
8.2 Timing for EUTs using communications channel-type transmissions.....	34
8.3 Duplex connections	35
8.4 Alternative monitoring interval	39
9. Test report.....	39
9.1 Test report contents	39
9.2 Applicable standards.....	39
9.3 Equipment units tested.....	40
9.4 Test configuration.....	40
9.5 List of test equipment	40
9.6 Units of measurement.....	40
9.7 Location of test site.....	40
9.8 Measurement procedures.....	40
9.9 Reporting measurement data	40
9.10 General and special conditions	41
9.11 Summary of results.....	41
9.12 Required signatures	41
9.13 Test report appendixes.....	41
9.14 Test report disposition	41
Annex A (informative) 47CFR15, Subpart D—Rules and test cases for UPCS devices.....	42
Annex B (informative) Radiated and conducted measurement of power output and monitoring thresholds.....	50
B.1 General.....	50
B.2 Power limits	51
B.3 Transmit power and monitoring threshold test method selection	52
B.4 General guidelines on measurement conditions and procedures.....	54
Annex C (informative) Options for implementing the tests of Clause 7 and Clause 8.....	55
C.1 Multicarrier interference generator	55
C.2 General.....	55
C.3 Alternative approaches.....	59

American National Standard Methods of Measurement of the Electromagnetic and Operational Compatibility of Unlicensed Personal Communications Services (UPCS) Devices

1. Overview

1.1 Scope

This standard sets forth uniform methods of measurement of the electromagnetic and operational compatibility of *unlicensed personal communications services* (UPCS) devices. This standard does not cover licensed *personal communications services* (PCS) devices. The recommended methods are applicable to the radio transmitter and monitoring devices contained in the UPCS device. These methods apply to the measurement of individual UPCS devices. Additional methods may be added to this standard to fulfill future requirements.

In addition to the measurements specified herein, UPCS devices may also be required to be tested in accordance with other standards. Examples are listed in Annex A.

1.2 Applications

The procedures given herein may be used to test UPCS devices permitted under 47CFR15, Subpart D.¹ The emissions and operational characteristics of UPCS devices are the basic parameters affecting UPCS coexistence with other electronic devices and systems. In particular, compliance with this standard may be used to demonstrate electromagnetic compatibility with other UPCS systems and other systems operating in the same and adjacent frequency bands.

¹ For information on references, see Clause 2.

This standard describes preferred test methods, test facilities and, in some cases, alternative test methods and facilities. If these methods and facilities do not apply to the equipment under test (EUT), the manufacturer must explain why and must provide an alternative test procedure that has been approved by the applicable regulatory agency. If alternative test methods or facilities are employed, every effort should be made to establish correlation with the preferred ones.

Where the word *shall* is used in this document, it indicates something that is mandatory for compliance with this standard. The word *should* indicates something that is advisory only.

1.3 Roadmap to the document

The tests for UPCS devices fall into two categories. The first category includes the traditional set of radio-frequency (RF) measurements of radiated power, emission mask, power spectral density (PSD), etc. These tests are given in Clause 6 of this standard. The second category includes tests for the channel monitoring and access requirements unique to UPCS devices. These requirements are sometimes collectively referred to as the spectrum etiquette. The associated tests are described in Clause 7 and Clause 8 of this standard, and relate to 47CFR15.323. Section 15.323 of Title 47 of the Code of Federal Regulations requires that a UPCS device (the EUT) monitor the received RF power level on the intended transmit channel² before transmitting, and it also provides criteria that the monitored power level must satisfy to allow the EUT to transmit on that channel. The tests in Clause 7 and Clause 8 are designed to verify compliance with these requirements. Annex A provides a table showing the sections in 47CFR15 that correspond to the tests in this document.

To test for compliance with the monitoring and access requirements, it is necessary to subject the EUT to deliberate interference with controlled spectral and temporal characteristics on a selected channel or channels, and observe the reaction of the EUT. To restrict operation of the EUT to the selected channel(s), interference or administrative commands are used to block the other channels.

Clause 6, Clause 7, and Clause 8 give the fundamental tests. Clause 4 discusses test methodology for both radiated and conducted RF emission, monitoring, and access tests. Radiated tests measure field strength to determine the effective isotropic radiated power (EIRP), power density, and out-of-band emissions (Clause 6). For the monitoring and access tests of Clause 7 and Clause 8, a calibrated field strength is applied to the EUT if radiated measurements are used. If all EUT antennas are detachable, the tests of Clause 6, Clause 7, and Clause 8 shall be done on a conducted basis; that is, RF connections can be made between the EUT, its companion device, and the RF measuring instrument and interference generators via shielded coaxial cable. There must be adequate shielding around the EUT (and possibly the companion device) to prevent unintended RF coupling.

Clause 5 provides guidance on selection of measurement instrumentation, and Clause 9 summarizes the information that should be provided in the test report.

2. Normative references

The following referenced documents are indispensable for the application of this document. For dated references, only the edition cited applies. For undated references, the latest edition of the referenced document (including any amendments or corrigenda) applies.

ANSI C63.4-2003, American National Standard for Methods of Measurement of Radio-Noise Emissions from Low-Voltage Electrical and Electronic Equipment in the Range of 9 kHz to 40 GHz.³

² “Channel” is used here to denote a time/spectrum window.

³ ANSI publications are available from the Sales Department, American National Standards Institute, 25 West 43rd Street, 4th Floor, New York, NY 10036, USA (<http://www.ansi.org/>).

ANSI C63.14-1998, American National Standard Dictionary for Technologies of Electromagnetic Compatibility (EMC), Electromagnetic Pulse (EMP), and Electrostatic Discharge (ESD).

Code of Federal Regulations Title 47 Part 2 (47CFR2), Frequency Allocations and Radio Treaty Matters: General Rules and Regulations.⁴

Code of Federal Regulations Title 47 Part 15 (47CFR15), Subpart D, Telecommunication—Radio Frequency Devices—Unlicensed Personal Communications Service Devices.

IEEE Std 149™-1979, IEEE Standard Test Procedures for Antennas.^{5, 6}

3. Definitions, symbols, acronyms, and abbreviations

3.1 Definitions

For the purposes of this standard, the following terms and definitions apply. IEEE 100™, *The Authoritative Dictionary of IEEE Standards Terms*, Seventh Edition, and ANSI C63.14-1998, unless otherwise noted in the definitions of this clause, apply throughout this document. Definitions in particular product standards or in applicable regulations take precedence.

3.1.1 activate: Apply power to the EUT; the EUT is running, but user-level communication is not occurring. For example, for a voice system after activation, the two ends of the link are synchronized, but no voice communication has begun. *See also:* **initiate**.

3.1.2 bandwidth, emission, B: The bandwidth in hertz of the signal between two points, one below the carrier center frequency and one above the carrier center frequency, that are 26 dB down relative to the maximum level of the modulated carrier. It is based on the use of measurement instrumentation employing a peak detector function with an instrument resolution bandwidth (RBW) approximately equal to 1.0% of the measured emission bandwidth of the EUT [see 47CFR15.303(c)].

3.1.3 channel: A repeated time and spectrum combination used for communications. In 47CFR15.323(c), the FCC uses the description a “combined time and spectrum window.” In this standard, channel and access channel have the same meaning.

3.1.4 communications channel: A repeated time and frequency window whose primary purpose is the transmission of user-level communications. *See also:* **control and signaling channel**.

3.1.5 conducted emission and monitoring tests: Tests performed with RF signal sources (to test monitoring thresholds) and instrumentation (to measure emissions) connected directly to the antenna port on the EUT transceiver through appropriate RF attenuation, if applicable, via shielded coaxial cable and passive combiner/splitter networks. *See also:* **radiated emission and monitoring tests**.

3.1.6 control and signaling channel: A repeated time and frequency window whose exclusive purpose is the transmission of information used by a system incorporating the EUT to maintain timing synchronization or other information that does not require repeated and ongoing acknowledgement (e.g., a beacon used to broadcast a timing synchronization and identification signal). *See also:* **communications channel**.

⁴ U.S. Regulatory Guides are available from the Superintendent of Documents, U.S. Government Printing Office, P.O. Box 37082, Washington, DC 20013-7082, USA (<http://www.access.gpo.gov/>).

⁵ The IEEE standards or products referred to in this clause are trademarks of the Institute of Electrical and Electronics Engineers, Inc.

⁶ IEEE publications are available from the Institute of Electrical and Electronics Engineers, 445 Hoes Lane, P.O. Box 1331, Piscataway, NJ 08855-1331, USA (<http://standards.ieee.org/>).

3.1.7 different collocated: Two or more antennas of substantially differing gains or efficiencies, with a mutual separation distance of 1 m or less, mounted on or within one housing, for the purpose of providing diversity against multipath fading.

3.1.8 digital modulation: The process by which the characteristics of a carrier wave are varied among a set of predetermined discrete values in accordance with a digital modulating function.

3.1.9 frame jitter: Time-related, abrupt, spurious variations in the duration of the frame interval.

3.1.10 frame period: A set of consecutive time slots in which the position of each time slot can be identified by reference to a synchronizing source.

3.1.11 frequency administration commands: Means of control of the EUT directly or through the companion device. This functionality is provided by the manufacturer to ease testability of the EUT. This functionality may include providing a control operator with external controls enabled to force the EUT to use only one or a subset of all the available carriers, and/or one or a subset of all of the available timeslots, and/or to disable diversity antenna selection. Functionality may be provided by the setting of unique values within nonvolatile memory in the EUT or companion device, or by other means not at variance with the requirements of 47CFR15.

3.1.12 identical collocated: Two or more antennas of the same type, with substantially similar performance and with a mutual separation distance of 1 m or less, mounted on or within one housing, for the purpose of providing diversity against multipath fading.

3.1.13 initiate: Cause the EUT to attempt to begin user-level communications, typically via the user interface, or in response to user-level data. For example, for a voice system, to initiate, press the ‘TALK’ control to enable voice communications. *See also:* **activate.**

3.1.14 initiating device: A UPCS device that monitors both duplex channels of a duplex transmission pair in order to qualify both its own and a responding device’s transmit channel for compliance with the spectral etiquette. *See also:* **responding device.** This capability is used in accordance with 47CFR15.323(c)(10) to simplify the implementation of a UPCS system.

3.1.15 listen before transmit (LBT): An interference avoidance mechanism that mandates monitoring of a selected channel to determine availability before transmission.

3.1.16 least interfered channel (LIC): An interference avoidance mechanism that extends the LBT mechanism to monitor all potential channels, determining the LIC, before transmitting on that channel. Under 47CFR15.323, this mode of operation is limited to those systems with 40 or more channels.

3.1.17 operational failure: The inability of an EUT to perform a function that is required as a response to system conditions or to a manually or automatically initiated command.

3.1.18 peak transmit power, P_{EUT} : The peak power output observed over an interval of time equal to the transmission burst duration of the EUT under all conditions of modulation.

3.1.19 power spectral density (PSD): The peak pulse power measured in a defined bandwidth.

3.1.20 radiated emission and monitoring tests: Tests performed with RF signal sources (to test monitoring thresholds) and instrumentation (to measure emissions) connected to test antennas. *See:* **conducted emission and monitoring tests.**

3.1.21 reaction time: The reaction time is the minimum duration of the interference present during the monitoring interval that must be detected by the EUT so as to determine that the monitored time and spectrum window is occupied.

3.1.22 responding device: A UPCS device that does not monitor its own transmit channel, but rather operates in partnership with an initiating device, which monitors both duplex channels of a duplex transmission pair in order to qualify both its own and the responding device's transmit channel for compliance with the spectral etiquette. *See also: initiating device.* This capability is used in accordance with 47CFR15.323(c)(10) to simplify the implementation of a UPCS system.

3.1.23 spectrum window: An amount of spectrum bandwidth equal to the intended emission bandwidth in which operation is desired.

3.1.24 thermal noise power: The noise power in watts defined by the formula $N = kTB$, where N is the noise power in watts, k is Boltzmann's constant, T is the absolute temperature in degrees Kelvin (e.g., 295 K), and B is the emission bandwidth of the EUT in hertz.

3.1.25 time window: An interval of time in which transmission is desired.

3.1.26 threshold, lower, T_L : The level of other-user signal that constitutes the maximum threshold for an active channel for the EUT's LBT algorithm if the EUT system supports less than 40 channels, taking into account the transmission bandwidth and actual transmit power of the EUT.

3.1.27 threshold, upper, T_U : The level of other-user signal that constitutes the maximum threshold for an active channel for the EUT's LBT algorithm if the EUT system supports 40 or more channels and incorporates an LIC function, taking into account the transmission bandwidth and actual transmit power of the EUT.

3.1.28 unlicensed personal communications service (UPCS) device: Intentional radiators operating in the frequency band specified by the applicable regulating agency that provide a wide array of mobile and ancillary fixed communication services to individuals and businesses without requiring operational license from the regulatory agency.

3.2 Symbols

3.2.1 $B_{\text{limit}U}$: The measured emissions bandwidth must be less than $B_{\text{limit}U}$ [see 47CFR15.323(a)].

3.2.2 $B_{\text{limit}L}$: The measured emissions bandwidth must be greater than $B_{\text{limit}L}$ [see 47CFR15.323(a)].

3.2.3 D : The largest linear dimension of the body of the EUT.

3.2.4 E_{EUTmax} : The maximum field strength of radiated emissions at the angle and polarization of maximum antenna gain.

3.2.5 G : Antenna maximum gain above which maximum allowable transmit power is reduced [see 47CFR15.319(e)].

3.2.6 G_A : EUT antenna gain at the angle and polarization of maximum gain, expressed as decibels relative to isotropic antenna gain (dBi).

3.2.7 M_L : The maximum amount in decibels by which the lower threshold may exceed thermal noise for an EUT transmitting the maximum allowed power.

3.2.8 M_U : The maximum amount in decibels by which the upper threshold may exceed thermal noise for an EUT transmitting the maximum allowed power.

3.2.9 P_{limit} : The peak transmit power that the EUT must not exceed, taking into account antenna gain (G_A) and emissions bandwidth.

3.2.10 P_{max} : The peak transmit power that the EUT must not exceed, if antenna gain is less than G , taking into account emissions bandwidth.

3.2.11 PSD_{EUT} : The EUT's maximum of peak transmit power measured in any 3 kHz bandwidth.

3.2.12 $\text{PSD}_{\text{limit}}$: The peak transmit power in any 3 kHz measurement bandwidth that the EUT must not exceed.

3.2.13 P_{Tref} : The power to be applied to a reference antenna input connector on a radiated test range, at a level necessary to achieve the desired signal level at the EUT.

3.2.14 U_M : Margin of 6 dB for uncertainty in the threshold measurements, incorporating the effects of EUT measurement noise and uncertainty.

3.3 Acronyms and abbreviations

CW	continuous wave
dBc	decibels relative to the total carrier power
dB _i	decibels referenced to isotropic antenna gain
dB _m	decibels referenced to one milliwatt
dB μ V/m	field strength in decibels referenced to one microvolt per meter
EIRP	effective isotropic radiated power
EUT	equipment under test
k	Boltzmann's constant
LBT	listen before transmit
LIC	least interfered channel
LVDS	low-voltage differential signaling
M_L	lower interference threshold (decibels above thermal)
M_U	upper interference threshold (decibels above thermal)
OATS	open-area test site
PCS	personal communications services
ppm	parts per million
PSD	power spectral density
RBW	resolution bandwidth
RF	radio frequency
TDD	time-division duplexing
TDMA	time-division multiple access
TEM	transverse electromagnetic
T_M	received signal level threshold, upper or lower as appropriate
T_L	the lower threshold for deferral
T_U	the upper threshold for deferral
U_M	provision for measurement uncertainty and noise
UPCS	unlicensed personal communications services
VHDCI	very high density cable interconnect

4. Radiated and conducted emissions test methodology

To perform the RF emission tests in Clause 6 and the monitoring and access tests in Clause 7 and Clause 8, it is necessary to have controlled RF paths between the EUT and the measurement instrumentation, as well as between the EUT and the interference generators. If the EUT requires a companion device to operate, there must also be a controlled RF path between the EUT and its companion device.

These controlled RF paths may be realized either as “radiated” (through space) or “conducted” (over coaxial cable) paths. In the radiated case, the tests must be performed in a facility with controlled RF propagation characteristics, so that the path loss can be controlled by varying separation between transceiver and monitoring/source antennas. In the conducted case, the tests can be performed anywhere there is adequate shielding to prevent external interference from affecting the test results. Signals can be combined and distributed using passive networks (e.g., hybrids, RF attenuators, Butler matrices,⁷ directional couplers). Path loss can be controlled with RF attenuators.

This clause provides guidance on implementation of the conducted and radiated measurements of transmit power and monitoring threshold. Supporting derivations are given in Annex B.

Conducted tests are preferred to radiated tests, and should be used for tests not affected by antenna selectivity if the EUT antenna can be detached for testing purposes. If the EUT antenna or antennas are replaced by a direct connection, the connection should be made in an impedance-matched fashion so that matching losses relative to the antenna connection are less than 2 dB.

4.1 Test facilities and equipment

Tests should be performed at the manufacturer's recommended normal operating temperature and voltage.⁸ Unless stated otherwise, the requirements of ANSI C63.4-2003 apply to the test facilities, including the site design, dimensions, and validation. Additional site validation requirements above 1 GHz are currently under development. Portions of this standard place requirements on the test facilities, in addition to the general requirements of ANSI C63.4-2003.

When shielding facilities (shielded room, semi-anechoic chamber or anechoic chamber) are used for operational compatibility testing, the shielding effectiveness of the room shall be such as to ensure compliance with electromagnetic emission limits for the environment outside of the room and reduce the ambients penetrating into the room to levels at least 10 dB below the weakest measured signal.

When the free-space test environment is simulated, the reflections from the facility confines, as well as the reflections from any extraneous objects at the test site, must be reduced to levels at least 10 dB below the direct (free-space) signal.⁹

The diagram in Figure 1 lists the types of test facilities that may be used for measurements specified in this standard.

In all cases, the test facilities and equipment must be fit for the purpose of measuring the parameters and operations of the EUT according to the requirements of 47CFR15, and in accordance with good engineering practice.

⁷ A Butler matrix is a network of 3 dB hybrids that provides a passive combining/splitting function for coupling multiple RF inputs to multiple RF outputs.

⁸ Use ambient conditions unless otherwise specified as in Table 7. Nominal mains voltage of 115 V (ac) (or fresh battery pack as appropriate) may be used.

⁹ To check for reflections or other influence from nearby objects move the EUT one-quarter-wavelength relative to the structure, repositioning the measurement antenna or probe, so as to keep the same relative spacing between the EUT and measurement antenna or probe. Compare the results. The EUT may also be reoriented by 45° or 90° and measured.

The RF ambient and instrumentation noise floor shall be > 20 dB below the intended measurement limit.

If it is not practical to measure the reflection loss, then the two-wavelength spacing rule may be used. By this rule, all potentially reflective objects are kept greater than two wavelengths away from the EUT.

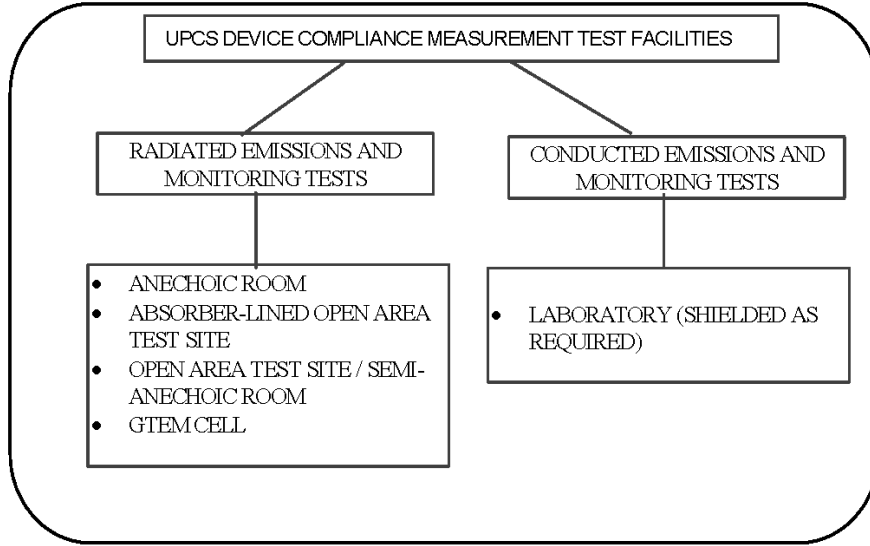

Figure 1—Test facilities that may be used

4.2 Test configurations and setup

Clause 6 provides detailed tests of parameters related to RF emissions, such as peak transmit power, emission bandwidth, and PSD. Those tests are similar to emission tests performed on most non-UPCS devices. Clause 7 and Clause 8 provide tests that verify compliance with the monitoring and access requirements that are unique to UPCS devices. These tests require observation of the electrical performance characteristics of the EUT in the presence of controlled interference of a specific frequency, power level, and modulation format. The monitoring and access tests have implications for the conducted and radiated test setups.

The *monitoring antenna* refers to the EUT antenna used to monitor the RF signal on the channel prior to transmission. In many cases, the monitoring antenna will be the same as the transmitting antenna. If it is not, then the monitoring and access tests are further complicated by the need to ensure that the monitoring antenna provides “coverage” that is at least equivalent to that which would be provided by the transmit antenna.

This standard identifies six test configurations. Each configuration is discussed in a separate subclause as shown in Table 1.

Table 1—Test specifications for different antenna configurations

Transmit/monitoring	Subclause	
	Conducted measurement based test (preferred)	Radiated measurement based test
Single, or identical collocated	4.5	4.8
Different collocated	4.6	4.9
Arbitrarily placed	4.7	4.10

Independent of antenna type and placement, the measurement type (i.e., conducted or radiated) can be selected by the product manufacturer and specified in the compliance report. Conducted measurements are generally required for systems with detachable antennas for measurements where antenna frequency selectivity is not a factor.

Compliance measurements utilize standard EMC and antenna techniques for conducted power, radiated field, and EIRP measurements. The conducted test setup is based on power measurements at the EUT transmit, receive, and monitoring antenna terminals. The associated compliance limits for the UPCS products depend on the transmit antenna gain G_A . The value of G_A is declared by the manufacturer.

Since the transmitter and receiver radiated power parameters can be expressed in several different but equivalent ways, a number of alternative compliance test procedures can be used for radiated measurements. The general radiated test setup is based on free-space environment measurements as shown in Figure 2, where D is the largest dimension of the EUT (see Figure 3 for the general conducted test setup). The free-space test site is defined such that the reflections from any ground planes and other reflecting objects are at least 10 dB below the line-of-sight signal. The reference antenna is used to measure the EUT radiating power and to establish the monitoring threshold fields at the transmit and monitoring antennas. The associated compliance limits are based on the EIRP. The antenna gain and the EIRP evaluations should be performed as recommended in IEEE Std 149-1979.

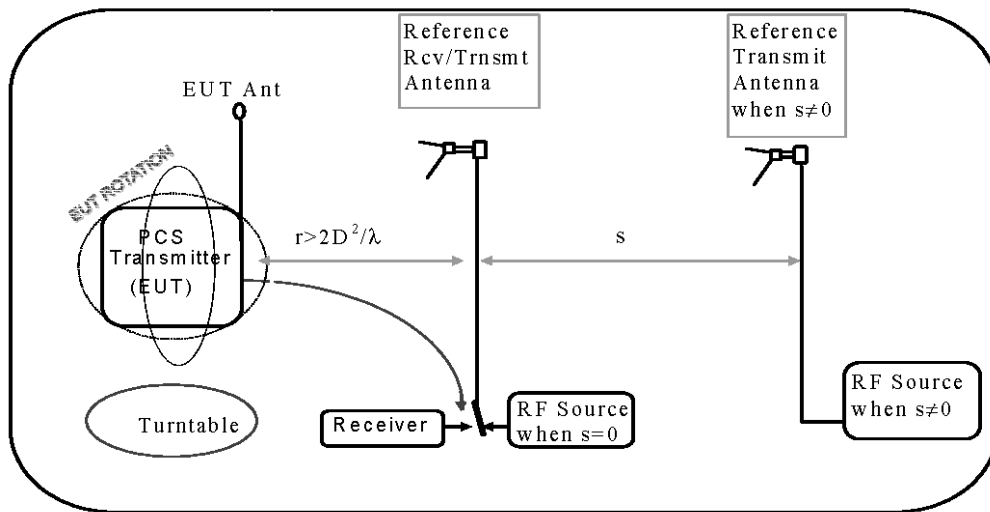

Figure 2—Radiated measurements in free-space environment

Equivalent radiated tests can be performed in facilities that do not provide for a free-space environment and/or measure radiated power (wideband transverse electromagnetic (TEM), etc.). Instead of using the reference antenna, the necessary power levels are generated and/or measured by the test facility itself. If alternative measurements are used, the test results must be correlated with those obtained using antenna measurements in a free-space environment.

4.3 Transmitted power and monitoring threshold limits

The spectrum etiquette for UPCS systems requires that one or both ends of a linked pair monitor a channel for other users in proximity, prior to transmitting. The EUT must defer using the channel if the amount of other-user signal detected is above a threshold. EUT systems that support a large number of users and implement the LIC algorithm are permitted to use an upper threshold for interference; EUT systems that

support a lesser number of users or do not implement the LIC algorithm are required to use a lower threshold. EUT transmit power is also limited, and the thresholds are adjusted to normalize the anticipated interference generated by an EUT in proportion to its transmit power.

4.3.1 Peak transmit power

P_{EUT} , the EUT transmit power at the antenna terminals, must be less than a maximum, as shown in the following equation:

$$P_{EUT} \leq P_{limit} \text{ where } P_{limit} = \begin{cases} P_{max} - (G_A - g), & \text{when } G_A > g \\ P_{max}, & \text{when } G_A \leq g \end{cases} \quad (1)$$

where

- P_{max} is equal to $5 \log B - 10$ dBm, or $10^{-4} \sqrt{B}$ W, from 47CFR15.319(c)
- B is the emission bandwidth (in hertz)
- G_A (dBi) is the EUT transmit antenna maximum gain (declared by the manufacturer)
- g is the allowable excess gain over that of an isotropic antenna without a transmit power reduction¹⁰

4.3.2 Peak transmit PSD

PSD_{EUT} , the peak EUT transmit power at the antenna terminals measured in a 3 kHz bandwidth, must be less than PSD_{limit} , as follows:

$$PSD_{limit} = 3 \text{ mW/3kHz, from 47CFR15.319(d)} \quad (2)$$

4.3.3 Upper monitoring threshold

The EUT's upper monitoring threshold power at the monitoring antenna terminals shall be less than a maximum, as shown in the following equation:

$$T_U \leq (-174 + 10 \log B + M_U + P_{max} - P_{EUT}) \text{ dBm} \quad (3)$$

M_U is a level specified in 47CFR15.323(c) and is the maximum amount in decibels by which the upper threshold may exceed thermal noise for an EUT transmitting the maximum allowed power.

4.3.4 Lower monitoring threshold

The EUT's lower monitoring threshold power at the monitoring antenna terminals shall be less than a maximum, shown in the following equation:

$$T_L \leq (-174 + 10 \log B + M_L + P_{max} - P_{EUT}) \text{ dBm} \quad (4)$$

M_L is a level specified in 47CFR15.323(c) and is the maximum amount in decibels by which the lower threshold may exceed thermal noise for an EUT transmitting the maximum allowed power.

¹⁰ 47CFR15.319(e) specifies that $g = 3$ dBi.

4.4 Limits for radiated and conducted tests

When conducted tests are performed, the limits from Equation (1), Equation (2), and Equation (3) or Equation (4) in 4.3.1 through 4.3.4 apply directly. For radiated tests, those limits must be translated to the equivalent limits on EIRP and monitoring threshold field strength, respectively. EIRP limits corresponding to Equation (1) are given in the following equation:¹¹

$$\text{EIRP}_{\text{EUT}} \leq \begin{cases} P_{\text{max}} + g, G_A > g \\ P_{\text{max}} + G_A, G_A \leq g \end{cases} \quad (5)$$

To test for monitoring threshold compliance using radiated techniques, a reference antenna is used to generate the required field strength at the monitoring antenna. The EUT's antenna gain affects the EUT's radiated interference level into other users intended to be protected by the LBT and LIC provisions, and the test for monitoring compliance needs to account for this. Accordingly, the transmit power P_{Tref} that must be applied to the reference antenna terminals to induce the effective signal detectable by the EUT's monitoring elements can be expressed in terms of the EUT's antenna gain as follows:

$$P_{\text{Tref}} = T_M - G_A - 20 \log(\lambda/4\pi r) - G_{\text{REF}} \quad (6)$$

where

- T_M is the desired signal level received by the EUT
- G_A (dBi) is the EUT's antenna gain in the direction and polarization of maximum
- G_{REF} (dBi) is the gain of the reference antenna in the direction of the EUT and copolarized
- λ is the signal wavelength in meters
- r is the distance from the reference antenna to the EUT monitoring antenna in meters

4.5 Conducted measurements of products with identical collocated transmitting and monitoring antennas

Disconnect the EUT antenna and measure power P_{EUT} at its terminals during EUT transmission, as specified in Clause 6 of this standard. Measure the monitoring threshold(s) using the procedures in Clause 7 of this standard.

4.6 Conducted measurements of products with collocated transmitting and monitoring antennas of different types

When the monitoring antenna is different from the transmitting antenna, it must be verified that the monitoring antenna provides coverage equivalent to or better than that of the transmitting antenna. This means that the monitoring system shall cause deference to any transmission of sufficient strength to induce a power level in the EUT transmit antenna that exceeds the threshold for the EUT, measured at the transmitting antenna input.

The transmit power compliance test of Clause 6 shall be performed as stated in 4.5. Calculate the maximum appropriate threshold T_L or T_U using Equation (2) or Equation (3), and verify that the EUT transmits when interference power sufficiently less than T_L or T_U is applied to the monitoring antenna terminals and defers when interference power equal to or greater than T_L or T_U is applied to the terminals.

¹¹ Because the EIRP limit is independent of G_A for $G_A > 3$ dBi, and most practical radiating devices will not have a gain sufficiently below 3 dBi for the difference $3 \text{ dBi} - G_A$ to be accurately measurable, there may be a gain-independent EIRP limit in the future.

The equivalent coverage test for the transmitting and monitoring antennas is then performed as follows:

- a) Set up the reference antenna with controlled polarization and with its major lobe facing the EUT's direction of maximum transmit radiation, at a distance r (meeting the far-field conditions) from the EUT antennas. Apply a signal on the appropriate channel at power P_{Tref} (see definitions) to the reference antenna terminals to create the deferral test signal of Clause 7 at the desired level at the transmit antenna.
- b) Test to see that the EUT defers with vertical reference antenna polarization.
- c) Repeat the test with horizontal polarization for the reference antenna.

The EUT shall defer for one or the other of the two orthogonal reference antenna polarizations. Otherwise, it fails the equivalent coverage test.

4.7 Conducted measurements of products with arbitrarily placed transmitting and monitoring antennas

The transmit power compliance test of Clause 6 shall be performed as stated in 4.5. Calculate the maximum appropriate threshold T_L or T_U using Equation (2) or Equation (3) and verify that the EUT transmits when interference power sufficiently less than T_L or T_U is applied to the monitoring antenna terminals and defers when interference power equal to or greater than T_L or T_U is applied to the terminals.

The equivalent coverage test for the transmitting and monitoring antennas is then performed as follows:

- a) Set up the reference antenna with vertical polarization and with its major lobe facing the EUT at a distance r (meeting the far-field conditions) from the EUT transmit antenna in the direction of the EUT's maximum radiation.
- b) Apply power to the reference antenna terminals and adjust it to the level P_{Tref} .
- c) Move the reference antenna (without changing its orientation) in the direction of the EUT's maximum radiation to a distance $r + s$ from the monitoring antenna, where s is the maximum possible distance between the transmit and monitoring antennas, as specified by the EUT manufacturer.
- d) Align the EUT monitoring antenna such that the direction of its minimum sensitivity faces the reference antenna.
- e) Apply power P_{Tref} to the reference antenna and illuminate the EUT monitoring antenna.
- f) Repeat step e) with the reference antenna horizontally polarized.

The EUT shall defer with one or the other of two orthogonal polarizations of the reference antenna, or the EUT fails the equivalent coverage test.

4.8 Radiated measurements of products with identical collocated transmitting and monitoring antennas

Set up the EUT and reference antenna with its major lobe facing the EUT in the far field with separation r in meters. Initiate EUT transmission and find the direction of the EUT's maximum radiation. Measure the EUT EIRP. EIRP_{EUT} (dBm) can be calculated from the measured radiated field intensity in the direction of maximum radiation E_{EUTmax} using the following equation:

$$\text{EIRP}_{\text{EUT}} = E_{\text{EUTmax}} + 20 \log r - 104.8 \quad (7)$$

where

E_{EUTmax} given in decibels referenced to one microvolt per meter (i.e., dB μ V/m).

Using the nominal value of the EUT gain G_A declared by the manufacturer, calculate the limit on EIRP_{EUT} using Equation (4) in 4.4. If EIRP_{EUT} exceeds the limit, it fails the test.

Compliance with the monitoring threshold limits is verified as follows:

- a) Using Equation (5), calculate the power P_{Tref} that must be applied to the reference antenna terminals to establish the monitoring threshold field level at the EUT transmit antenna.
- b) Apply power first smaller than and then equal to P_{Tref} to the reference antenna terminals and illuminate the EUT in the direction of maximum radiation, while continuously attempting to initiate the EUT transmission. Verify that there is at least one position of the EUT in which it will transmit when sufficiently low power is applied to the reference antenna terminals.
- c) When the power level applied to the reference antenna is equal to or larger than P_{Tref} , the EUT shall defer for one or the other of two orthogonal polarizations of the reference antenna (e.g., vertical and horizontal). Otherwise, it fails the test.

4.9 Radiated measurements of products with collocated transmitting and monitoring antennas of different types

Set up the EUT and reference antenna with its major lobe facing the EUT in the far field with separation r . Perform the transmission test as described in 4.8 and verify that EIRP_{EUT} meets the limits.

Compliance with the monitoring threshold limits is verified using the same procedure as in 4.8.

4.10 Radiated measurements of products with arbitrarily placed transmitting and monitoring antennas

Set up the reference antenna with its major lobe facing the EUT in the far field with separation r . Perform the transmission test as described in 4.8 and verify that EIRP_{EUT} meets the limits.

The equivalent coverage test for the transmitting and monitoring antennas is performed as follows:

- a) Calculate, as described in 4.8, the power P_{Tref} that must be applied to the reference antenna to establish the monitoring threshold field at the EUT transmit antenna.
- b) Move the reference antenna (without changing its orientation) in the direction of the EUT maximum radiation at a distance $r + s$ from the monitoring antenna, where s is the maximum possible separation distance between the transmit and monitoring antennas, as specified by the EUT manufacturer.
- c) Apply power, first smaller than and then equal to and larger than P_{Tref} to the reference antenna terminals and illuminate the EUT monitoring antenna. Investigate a number of the EUT monitoring antenna placements and positions on the surface of a sphere around the EUT monitoring antenna, as described in 4.8, while attempting to initiate transmission. There should exist a sufficiently low reference antenna power level (smaller than P_{Tref}) such that the EUT is able to transmit at least at one EUT antenna position.
- d) When the power level applied to the reference antenna is equal to and larger than P_{Tref} , the EUT shall defer at all positions of the monitoring antenna, for either horizontal or vertical reference antenna polarizations. Otherwise, it fails the test.

4.11 Manufacturer's declarations and descriptions

Before testing, the manufacturer shall provide declared values of the following parameters for the EUT being tested to the testing organization:

- The channel plan
- Maximum EUT antenna gain G_A (dBi), and orientation and polarization for maximum gain
- Maximum peak power level
- Emission bandwidth
- Nominal receive bandwidth
- Frame period and time slot plan, if time-division multiple-access (TDMA) techniques are used
- Minimum and maximum burst length, if TDMA techniques are used
- Minimum and maximum operating temperature ranges declared to the end user
- Whether a system built with the EUT does or does not operate under the provisions of 47CFR15.323(c)(10) to test for deferral only in conjunction with a companion device
- Whether a system built with the EUT does or does not implement the provisions of 47CFR15.323(c)(5) enabling the use of the upper threshold for deferral
- The nominal value of the deferral threshold
- Whether a system built using the EUT does or does not operate under the provisions of 47CFR15.323(c)(6) incorporating provisions for waiting for a channel to go clear
- Whether a system built using the EUT does or does not operate under the provisions of 47CFR15.323(c)(11) enabling the access criteria check on the receive channel while in the presence of collocated interferers
- The provisions within the EUT for self-check, by which compliance with 47CFR15.319(f) is obtained
- Whether the EUT does or does not have the monitoring made through the radio receiver used for communication
- Whether the EUT does or does not transmit control and signaling channel(s)
- Nominal mains and battery voltage

The manufacturer shall describe the channel monitoring and selection process used by the EUT, including details regarding the time between monitoring and transmission on the confirmed channel. Appropriate timing diagrams shall be included as necessary.

If the manufacturer claims exemption from the tests of 7.4, then the manufacturer shall declare and provide proper evidence that the monitoring is made through the radio receiver used for communication.

5. Measurement instrumentation

See informative Annex C.

6. RF measurements

6.1 Emissions tests

6.1.1 Test requirements

The equipment configured as shown in Figure 3 is for the conducted method. If the radiated method is required, refer to test configurations in Clause 4. The EUT is arranged to communicate via a fixed carrier frequency between its transmitter and a compatible receiver. If the devices provide two-way communications, one should be designated as the transmitter under test. If the EUT is evaluated by a conducted measurement on an external port, the EUT and its associated compatible transceiver should be placed close enough to be able to establish a connection. Tests should be performed at the manufacturer's recommended normal operating temperature and supply voltage.

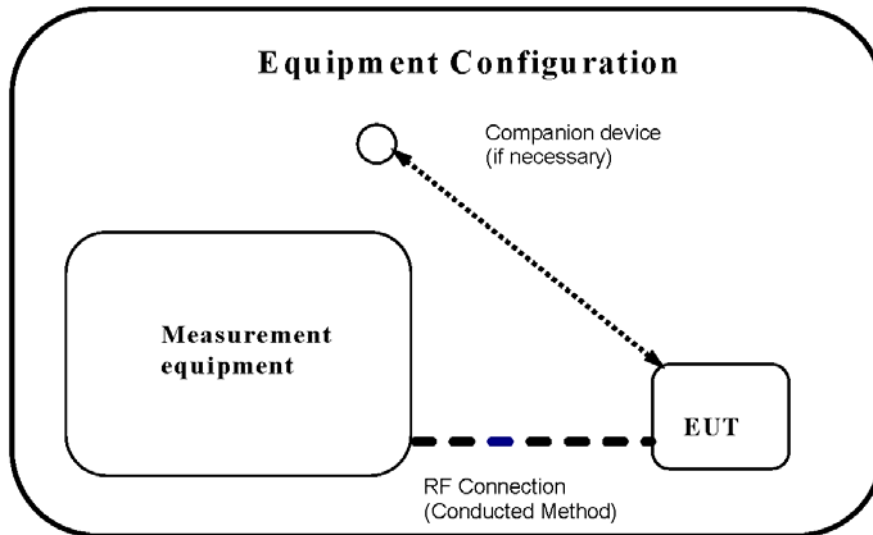

Figure 3—Test configuration

For conducted measurements, external RF attenuator and cable losses and instrumentation preamplifier gains shall be taken into account. For radiated measurement, cable losses, instrumentation preamplifier gains, and reference antenna factors shall be taken into account.

6.1.1.1 Transmitted digital sequences during emissions tests

The transmitted digital sequences during emissions tests shall be representative of those encountered in the real system operation. If emissions parameters are sequence-dependent, then the worst-case sequence expected to occur during normal operation shall be used.

6.1.1.2 Standard test frequencies for the emissions tests

For RF measurements, if the EUT is only capable of operation on a single frequency, then that is the standard test frequency.

Except as otherwise noted, if the EUT is capable of operation on more than one frequency within the band, then for RF measurements the standard test frequencies shall be the lowest frequency within the band for which the EUT is capable of operation, the highest frequency within the band for which the EUT is capable of operation, and the frequency nearest the center of the band for which the EUT is capable of operation.

6.1.2 Peak transmit power

The following test method may be used to verify that the EUT's peak transmit power does not exceed the permitted value. The equipment is configured as shown in Figure 3 and according to Table 2. The peak transmit power is the maximum of the RMS power during a transmit burst. Typical spectrum analyzers are frequency selective, peak-responding voltmeters calibrated to display the RMS value of a sine wave. Therefore, using the peak detection function on most spectrum analyzers will produce the intended measurement when the bandwidth and trigger functions are properly set.

Table 2—Spectrum analyzer settings for determining the peak power

RBW	\geq Emission bandwidth
Video bandwidth	\geq RBW
Span	Zero
Center frequency	Nominal center frequency of channels
Amplitude scale	Log (linear may be used if analyzer has sufficient linear dynamic range and accuracy)
Detection	Peak detection
Trigger	Video
Sweep rate	Sufficiently rapid to permit the transmit pulse to be resolved accurately

The RBW setting for this test must be adjusted by repeating this test and using increasing values of the RBW until there are negligible changes (within ± 0.5 dB) in the measured values of the maximum power.

The measured maximum shall be less than P_{limit} , or the EUT fails.

6.1.3 Emission bandwidth *B*

The equipment is configured as shown in Figure 3 and according to Table 3. The EUT shall transmit in a burst mode (shall not be configured to transmit continuously) so that transient effects associated with the burst edges are captured by the emission bandwidth measurement.

Table 3—Spectrum analyzer settings for measurement of emissions bandwidth *B*

RBW	Approximately 1% of the emission bandwidth (a rough estimate may be obtained from peak power level measurement, or use manufacturer's declared value)
Video bandwidth	$\geq 3 \times$ the RBW
Center frequency	Nominal center frequency of channel
Span	$\geq 2 \times$ the expected emission bandwidth
Sweep time	Coupled to frequency span and RBW
Amplitude scale	Log
Detection	Peak detection with maximum hold enabled

Record the maximum level of the modulated carrier. Find the two furthest frequencies above and below the frequency of the maximum level of the modulated carrier where the signal level is 26 dB below the peak level of the carrier. The difference in frequency between these two frequencies is the emission bandwidth. If, after measuring the emission bandwidth, it is found that the RBW used was not approximately 1% of the emission bandwidth, then adjust the RBW and repeat the procedure until the correct RBW is used. If the spectrum analyzer has fixed values of RBW, the one that is the nearest to 1% of the emission bandwidth is acceptable, provided it is no less than 0.5% of the emission bandwidth and no greater than 2% of the emission bandwidth.

Record the frequency of the maximum level of the modulated carrier and the furthest frequencies above and below this frequency where the signal levels are 6 dB and 12 dB below the peak level of the modulated carrier. These frequency pairs are to be used later in 7.4 for measuring monitoring bandwidth.

The measured B shall be less than B_{limitU} , or the EUT fails.

The measured B shall be greater than B_{limitL} , or the EUT fails.

6.1.4 Modulation

Attestation of compliance with the digital modulation requirement will be made in accordance with the disclosure statement required by the applicable equipment authorization procedures (see, e.g., 47CFR2).

6.1.5 Power spectral density PSD_{EUT} using the measured maximum method

The following test method may be used to verify that the EUT's PSD does not exceed the permitted value in any 3 kHz bandwidth.

The EUT transmit data sequence and mode of operation shall be representative of that encountered in normal operation, so that transient effects associated with transmission bursts or data content are captured by the PSD measurement. The equipment is configured as shown in Figure 3 and according to Table 4.

Table 4—Spectrum analyzer settings for finding of the maximum of PSD_{EUT}

RBW	3 kHz
Video bandwidth	$\geq 3 \times \text{RBW}$
Span	Zero span at frequency with the maximum level (frequency determined in 6.1.3 if the same type of signal (continuous versus burst) was used in 6.1.3)
Center frequency	Spectral peak as determined in 6.1.3
Sweep time	For burst signals, sufficient to include essentially all of the maximum length burst at the output of a 3 kHz filter (e.g., maximum input burst duration plus 600 μs). For continuous signals, 20 ms.
Amplitude scale	Log power
Detection	Sample detection and averaged for a minimum of 100 sweeps
Trigger	External or internal

For burst-type signals, arrange to measure the wideband burst duration of each burst analyzed and compute the mean duration.

Determine the level that is 20 dB below the first peak. Record the power-averaged waveform between the 20 dB threshold levels around the first peak with at least 30 000 samples per second as shown in Figure 4. Multiple wideband bursts may produce the waveform between -20 dB peaks; these must be included in the

determination of the average burst length. If there is no level that is 20 dB below the peak, then analyze the complete sweep and include all of the wideband waveform that occurs during the sweep time in the computation of average burst length.

Sum the values of the sample points (in linear units of power) and divide by the sample frequency to obtain the total pulse energy in the 3 kHz bandwidth, then divide by the average duration of the wideband input pulse to obtain the average pulse power. If the result is less than PSD_{limit} , the EUT passes the PSD requirement.

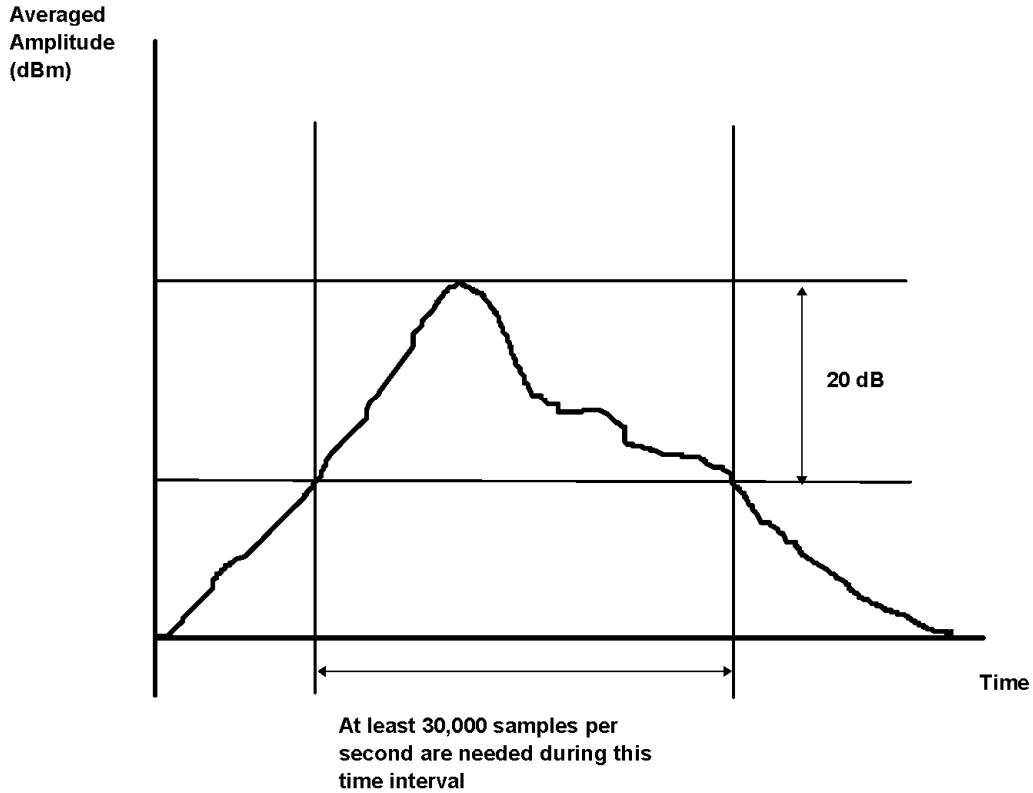

Figure 4—Computed average transient method: Sampling of the averaged power waveform measured with 3 kHz RBW

6.1.6 Emissions

Unless otherwise specified, the conducted method is the preferred method of measurement for in-band emissions. The radiated method may be used in-band if the EUT has nondetachable antenna(s), and should be used generally for out-of-band tests. A free-space environment or equivalent should be used in the radiated emission test. The general requirements for conducted and radiated tests are given in Clause 4 of this standard.

6.1.6.1 In-band unwanted emissions

The equipment is configured as shown in Figure 3 and using the settings listed in Table 5 as follows.

In the region between $1B$ and $2B$ from the center of the RF carrier, the measured emission level (measured with 1% of emission bandwidth) shall not exceed 30 dB below the permitted peak power for the EUT.

In the region between $2B$ and $3B$ from the center of the RF carrier, the measured emission level shall not exceed 50 dB below the permitted peak power for the EUT.

Table 5—Spectrum analyzer settings for measuring in-band emissions

RBW	Approximately 1% of the emission bandwidth (B)
Video bandwidth	$3 \times \text{RBW}$
Sweep time	The sweep time shall be sufficiently slow that the swept frequency rate shall not exceed one RBW per three transmit bursts.
Number of sweeps	Sufficient to stabilize the trace
Amplitude scale	Log
Detection	Peak detection and max hold enabled
Span	Approximately equal to $3.5 B$

In the region between $3B$ and the UPCS band edge, as measured from the center of the RF carrier, the measured emission level shall not exceed 60 dB below the permitted peak power for the EUT.

Where these limits are more stringent than 47CFR15.209, the limits of 47CFR15.209 take precedence as indicated in 47CFR15.319(g).

6.1.6.2 Out-of-band emissions

Out-of-band tests shall be performed with the RF carrier set to the lowest and highest carriers defined by the EUT. The spectrum analyzer settings for in-band unwanted emissions in 6.1.6.1 also apply to out-of-band emissions. The EUT shall pass the tests of item a), item b), and either item c) or item d).

- a) In the region between the band edges and 1.25 MHz below and above the lower and the upper band edges, respectively, the measured emission level shall not exceed -9.5 dBm.
- b) In the region between 1.25 and 2.5 MHz below and above the lower and the upper band edges, respectively, the measured emission level shall not exceed -29.5 dBm.
- c) In the region at 2.5 MHz or greater below and above the lower and upper band edges, respectively, the measured emission level shall not exceed -39.5 dBm.
- d) In the region at 2.5 MHz or greater below and above the lower and upper band edges, respectively, the measured emission level shall not exceed the limits of 47CFR15.209. Measurement shall be made as a radiated test.

UPCS devices, in general, include digital circuitry not directly associated with the radio transmitter and are subject to the requirements for unintentional radiators as described in 47CFR15.109, for both in-band and out-of-band emissions. These emissions shall be measured with the EUT operating in receive and transmit modes. For the transmit mode, do not measure within 3.75 MHz or $3B$, whichever is the largest, of the edges of the band. Emissions that are directly caused by digital circuits in the transmit path do not have to meet 47CFR15.109 limits, but shall meet those limits as mentioned in the preceding list.

6.2 Frequency and time stability

If the radiated method is used, refer to Clause 4 for configuration details. If the devices provide two-way communications, one should be designated as the EUT, with its transmitter under test, and the other is designated the companion device. If the conducted method is used, the EUT and its companion device may be connected with shielded coaxial cable through a splitter or similar device, or the companion device may be placed close enough to establish communications through radiation. An attenuator should be placed in the conducted path between the EUT and its companion device (if present) to prevent test results from being corrupted by emissions from the companion device. The attenuation should be adjusted to allow

reliable communication between the EUT and the companion device. Tests should be performed at the manufacturer's recommended normal operating temperature and voltage, unless otherwise specified.

The EUT may be configured using administrative commands to use a fixed channel during the tests.

6.2.1 Carrier-frequency stability

A demodulating spectrum analyzer, modulation analyzer, or frequency- and time-interval analyzer is configured as follows in Table 6 for carrier-frequency measurement:

Table 6—Measurement system configuration for carrier-frequency stability test

Y axis	Frequency
Center frequency	Nominal carrier center frequency
Frequency span	Span large enough so that the full waveform is greater than 50% but less than 100% of the display scale
X axis	Time
Time setting	Approximate transmit burst period, or 1 s for continuous transmissions
Trigger	RF envelope for pulsed systems; otherwise, frequency value

Measure the mean carrier frequency with minimum latency time between measurements.

Each mean carrier-frequency measurement is to be taken over a sample of EUT transmit signal encompassing at least 5000 transmitted bits but less than or equal to the number of bits transmitted in 1 s. For systems transmitting less than 5000 bits/s, the mean carrier-frequency measurement is to be taken over the number of bits transmitted in 1 s.

Alternatively, the mean frequency can be obtained using a frequency counter with gating time set at 5000 bit periods.

For systems incorporating a data bias (the number of positive frequency-shift and negative frequency-shift symbols are not equal over time), provisions for deriving the carrier-frequency by means of removing the modulation may be incorporated in the test.

6.2.1.1 Carrier-frequency stability over time

The mean value of the carrier frequency of the EUT should be recorded at least once every second for a total of greater than 3000 readings, or as rapidly as the measurement instrumentation permits over at least 1 h period of time, or over the interval for channel access monitoring, whichever is shorter. It may be necessary to use a controller to log the measurements if the analyzer does not have that capability.

The EUT passes if the maximum and minimum sample measurements of the mean carrier frequency differ from the average of the mean carrier-frequency sample measurements by 10 parts per million (ppm) or less.

6.2.1.2 Carrier-frequency stability over power supply voltage

In accordance with 47CFR15.323(f), this test does not apply to an EUT that is capable only of operating from a battery. For a mains-powered EUT, the mean value of the carrier frequency shall be measured at the power supply voltage extremes of row 1 of Table 7.

Table 7—Test parameters for carrier-frequency stability testing

Temperature	Supply voltage
20°C ± 2°C	85% to 115% of declared nominal voltage
-20°C ± 2°C	All declared nominal(s)
+50°C ± 2°C	All declared nominal(s)

The EUT passes if the mean carrier-frequency sample measurements at the extremes of power supply voltage differ from the average of the mean carrier-frequency sample measurements of 6.2.1.1 by 10 ppm or less.

6.2.1.3 Carrier-frequency stability over temperature

The mean value of the EUT carrier frequency shall be measured at the temperature extremes of Table 7, or at extreme temperatures as declared by the manufacturer.

The EUT passes if the mean carrier-frequency sample measurements at the extremes of temperature differ from the average of the mean carrier-frequency sample measurements of 6.2.1.1 by 10 ppm or less.

6.2.2 Frame-repetition stability

A demodulating spectrum analyzer, modulation analyzer, or frequency- and time-interval analyzer is configured as follows in Table 8 for the frequency measurement of the detected RF envelope:

Table 8—Measurement system configuration for frame-repetition stability test

X axis	Time
Time setting	Approximate frame period × 100
Y axis	Frequency
Center frequency	Nominal frame-repetition rate
Frequency span	Span large enough so that the full waveform is greater than 50% but less than 100% of the display scale.
Measurement time interval (gating time)	X (in units of frame period) where $X \leq 1000$
Number of measurements	1000/X (where X is the measurement interval in units of frame period)

The histogram of the frame timing distribution shall be computed with small or negligible latency time between measurements.

The analyzer settings in Table 8 will enable the mean frame-repetition rate measurement to be taken over a time period of at least 1000 frame periods. Alternatively, the mean frame-repetition rate may be obtained using an envelope detector and a frequency counter with gating time set at 1000 times the frame period.

The mean value of the frame-repetition rate should be recorded for a total of about 1000 readings or over at least 1 h period of time. It may be necessary to use a computer to log the measurements if the analyzer does not have that capability. A distribution of these 1000 readings should be recorded and its standard deviation computed. EUTs that implement time division for the purpose of maintaining a duplex connection shall maintain a frame-repetition rate whereby three times the standard deviation of the frequency stability shall

not exceed 50 ppm, not including a shift of the mean. Each EUT that further divides access in time shall maintain a frame-repetition rate whereby three times the standard deviation of the frequency stability shall not exceed 10 ppm, not including a shift of the mean.

6.2.3 Frame period and jitter

A demodulating spectrum analyzer, modulation analyzer, or frequency- and time-interval analyzer is configured as follows in Table 9 for frame period and jitter measurements.

Table 9—Measurement system configuration for frame period and jitter test

Y axis	Time
Center time	Frame period
Time span	Span large enough so that the full waveform is greater than 50% but less than 100% of the display scale.
X axis	Time
Time setting	Approximate frame period \times 100
Measurement time interval (gating time)	< Frame period (must be able to measure time interval between rising edge of one pulse to the rising edge of the next pulse within a resolution of 100 ns)
Number of measurements	100 000 frames total accumulated

Compute the histogram of the frame period distribution with small or negligible latency time between measurements.

When the accumulated number of measurements reaches 100 000, record the peak-to-peak, mean, and standard deviation values.

The mean value shall be the frame period and shall be 20 ms or 10 ms/X, where X is a positive integer. Three times the standard deviation value of the jitter shall not be greater than 12.5 μ s. Alternatively, jitter can be measured by using the analyzer to obtain the time duration between rising edges; use a computer to compute the difference between two consecutive frame periods. The difference between any two consecutive frame periods, measured over 100 000 frames, shall not exceed 25 μ s.

Deviation of the mean frame period from 20 mS or 10 mS/X shall be subtractive from the allowable jitter.

7. Monitoring tests

7.1 Introduction

The spectrum sharing rules require that EUTs monitor their intended channel (time and spectrum window) prior to transmission to sense RF energy in the channel. If there is RF energy above the monitoring threshold,¹² the EUT must either defer transmission until the channel is clear or select another clear channel. The monitoring tests in this subclause verify that the monitor levels, monitor timing, and deferral operation are in accordance with the spectrum sharing rules.

¹² See the calculation in 7.2.1 for details.

Difficulty in definitive monitoring testing comes from several potential sources as follows:

- EUTs may be designed to operate only together with other devices of like type.
- EUTs may select a channel or stop operating when interfering radio signals are detected in their channel.
- EUTs may transmit intermittently, and thus their modes of operation may be difficult to detect.

In the monitoring tests, interference is introduced to some unused regions of the band in order to confine the operation of the EUT to one region, or, if available, carrier and/or access channel administration commands are used to confine operation of the EUT to one region. For the purposes of many of the tests, it is sufficient to confine the EUT to operate in a restricted a region in the frequency domain, e.g., one or two carriers of the EUT. This is illustrated by Figure 5 and Figure 6. Since a channel is a combined time and spectrum window, for some tests it may be desirable to use gated interference to implement a similar restriction of operation in the time domain.

Administrative test commands are preferred when available. When using out-of-region interference, the power falling into the adjacent carrier of the EUT could potentially corrupt the test on the wanted carrier, especially if the EUT has poor adjacent channel rejection properties.

7.1.1 Monitoring test setup

Figure 5 illustrates the concept of operating regions within the band and shows how interference is provided outside of the operating region.

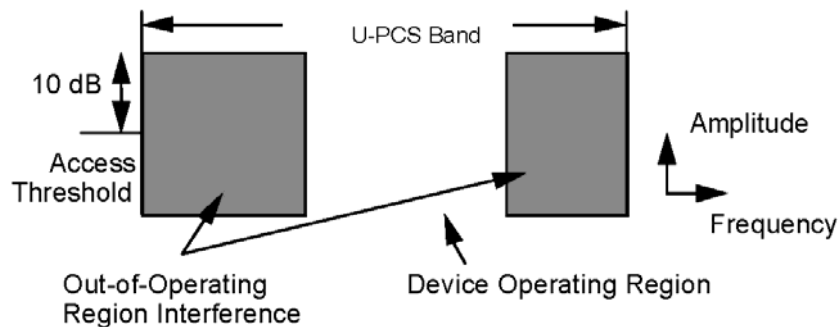

Figure 5—Operating region within UPCS band

Figure 6 illustrates the concept of adding interference into the selected operating region to test for compliance with the threshold limits. With this arrangement, the test requirement is to observe if the EUT transmits in the one region where the threshold is being tested. The out-of-operating-region interference is not required during the tests if the EUT is designed to operate in a single fixed channel of the UPCS band, or if the EUT can be restricted to selected channels using frequency administration commands.¹³

For the monitoring tests, the general equipment configurations are shown in Figure 7 and Figure 8. The EUT may be arranged to communicate via radio signals between itself and another compatible device (the companion device). Typically, the devices provide two-way communications, and one device should be designated as the monitoring transceiver under test (the EUT). Figure 7 illustrates radiated communication between the EUT and the instruments; Figure 8 illustrates conducted communication.¹⁴

¹³ Some UPCS devices may have the capability to restrict the device's operation to a subset of the available channels.

¹⁴ The interference antenna must transmit at least 10 dB higher power to the monitoring EUT than to the companion device. Otherwise, the operation of the EUT may be masked by the undesired response of the companion device to an above-threshold interference signal.

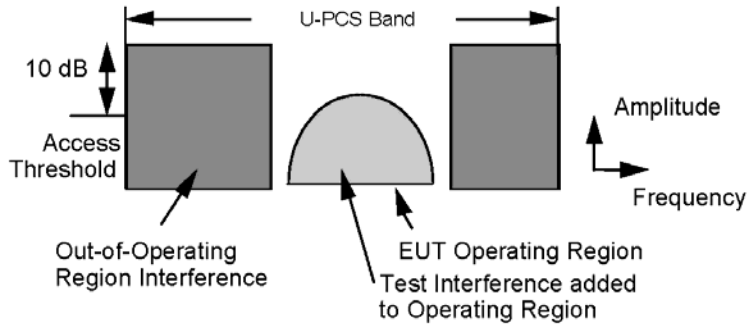

Figure 6—Interference added to operating region to test compliance

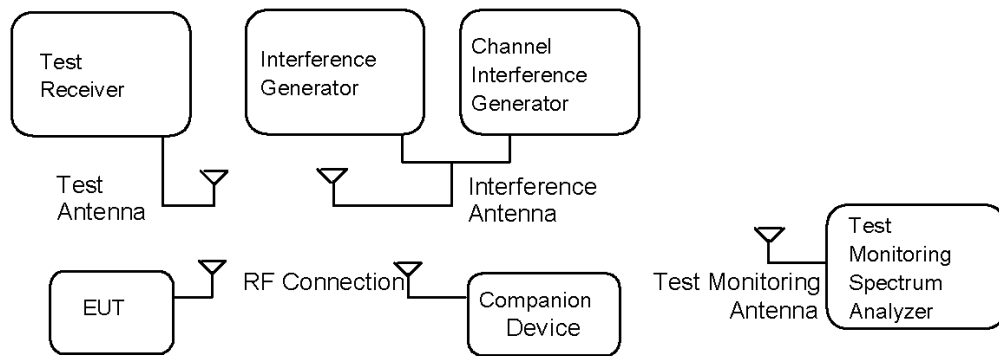

Figure 7—Possible equipment configuration for radiated monitoring and operational tests

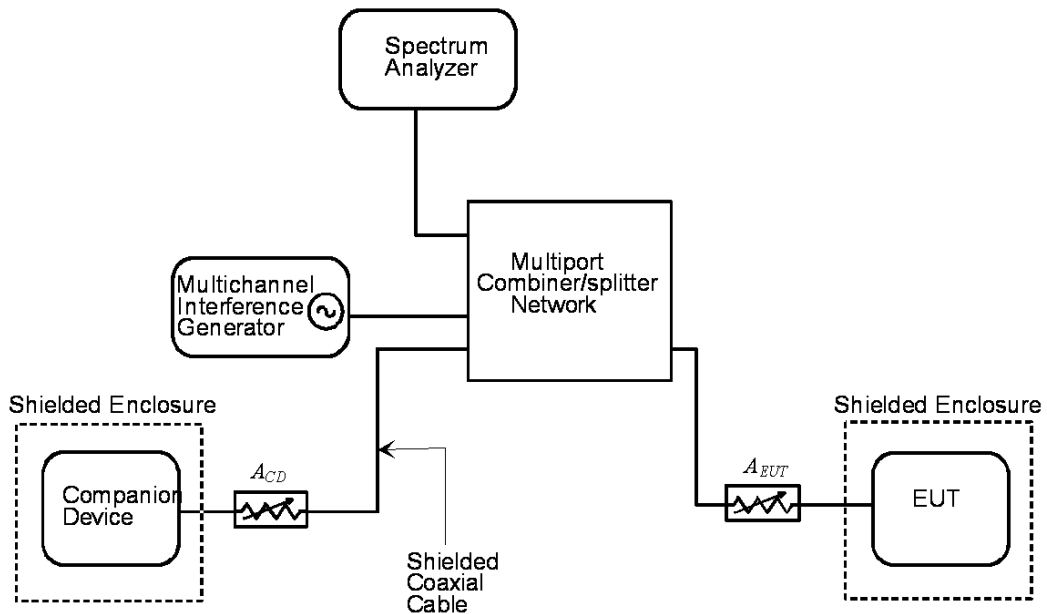

Figure 8—Possible equipment configuration for conducted monitoring and operational tests

7.1.2 Monitoring test procedure—general

The threshold used for channel access deferral is based on the power and emission bandwidth measurements of 6.1.2 and 6.1.3.

Each test will generally consist of the following steps:

- a) Using either carrier and/or access channel administration commands or out-of-operating-region interference (see 7.2.3), restrict operation of the EUT to a target channel or set of channels on which the test will be performed. Initiate transmission without the presence of interference on the target region to verify that the EUT is operating. The communication is then stopped.
- b) Introduce interference on the target channel or channels at the prescribed level and time duration as appropriate to the EUT and verify that the EUT defers use of that channel or channels when initiation of a connection is attempted.
- c) The EUT passes when it operates only in the allowed combinations of operating environments.

7.1.3 Standard test frequencies

Monitoring tests shall be performed on the carrier closest to the center of the band, except when two or all carriers are specified. When two carriers are specified, the carriers adjacent to the carrier closest to the center of the band may be used.

7.1.4 Timeslot and carrier equivalence

The monitoring procedure tests of Clause 7 that specify interference applied on various carriers may be implemented on a single carrier using interference synchronized with the timeslot structure, with the interference level adjusted by timeslot equivalently to the adjustments specified for interference present on individual carriers.

7.2 Calibration of levels

7.2.1 Calculation of thresholds¹⁵

Calculate the upper threshold limit T_U according to the provisions of 4.3.3, and the lower threshold limit T_L according to the provisions of 4.3.4.

7.2.2 Calibration of test interference field strength (radiated technique)

Refer to Clause 4 and Annex B.

7.2.3 Procedures for using out-of-operating-region interference

The multicarrier generator in C.1 is an interference source that can generate independently controlled (on or off) CW signals on the center frequencies of all EUT carriers. This generator can be used to apply out-of-operating-region interference to target specific frequency ranges or time intervals for threshold testing by blocking the other frequencies and/or timeslots, unless the frequency selectivity of the EUT is extremely poor. The procedures given here are intended to ensure that residual power from the generator falling on the target (unblocked) frequency does not corrupt the test.

¹⁵ See 47CFR15.321(c)(2), 47CFR15.321(c)(7), 47CFR15.323(c)(2), 47CFR15.323(c)(5), and 47CFR15.323(c)(9).

The target region normally has borders both in the frequency and time domains. Note that the procedure described in 7.2.3 only defines the borders in the frequency domain; no compensation is to be made for limited isolation in the time domain.

Figure 9 shows the relationships between the threshold being tested and the interference power levels discussed in this subclause. The objective is to create a situation in which the residual interference power level on the target frequency (due to imperfect frequency selectivity of the EUT) is Y dB below the regulatory threshold limit, while the power on the other (blocked) frequencies is X dB above the regulatory threshold limit. The multicarrier generator is adjusted so that the power on the frequency channel(s) adjacent to the target frequency is X_A dB above the threshold, where X_A can be up to 3 dB below X . $Z = X + Y$ represents the total decibel difference between the residual interference power on the target frequency and the interference on the blocked frequencies, except for the adjacent frequencies, for which the total decibel difference is $Z_A = X_A + Y$. Z and Z_A depend on the EUT frequency selectivity characteristic, typically determined by the intermediate frequency (IF) filtering. The way in which Z is divided between X and Y depends on the power level applied to the EUT from the interference generator on the blocked frequencies. The following procedures determine the proper level.

After out-of-operating-region interference is applied, it should be verified that the EUT is operating properly on the target frequencies.

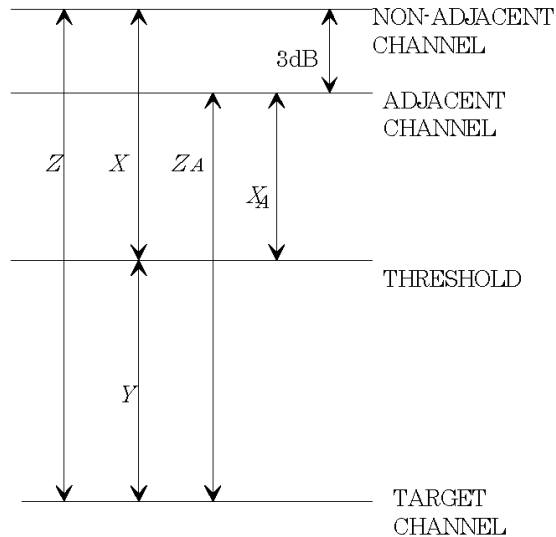

Figure 9—Relationships among power levels for out-of-operating-region interference

7.3 Deferral thresholds and channel selection¹⁶

These tests determine the lower and upper thresholds of the EUT and verify that if the EUT is operating in the LIC mode, it can properly select the channel with the lowest interference power, within a 6 dB resolution.

Some EUTs can transmit and be tested without a companion device, for example, devices transmitting signaling beacons. For those EUTs, a companion device may not be necessary for these tests. Other EUTs (typically handsets) cannot transmit without being locked to a control channel or beacon of a companion device (typically a base station). Therefore, when a companion device is required, the interference signals must be received by the companion device at a lower level, at least 10 dB lower, than the interference signals are received by the EUT. Otherwise, the operation of the EUT may be masked by the undesirable

¹⁶ See 47CFR15.323(b), 47CFR15.323(c)(2), and 47CFR15.323(c)(5).

deference response of the companion device. This implies that for the conducted case (Figure 8), the attenuation ACD shall be at least 10 dB higher than the attenuation AEUT. This is to ensure that the companion device does not defer transmissions due to interference on its transmit channel and/or corresponding duplex receive channel when the interference levels are set to a level appropriate to test the EUT. Furthermore, the signals from the companion device must be received by the EUT with much higher power (typically > 20 dB) than the power of the interference into the EUT. This is to ensure that the EUT can properly receive the transmissions from companion device when the interference levels are set to test the EUT. In addition, if the companion device is required to be able to receive signals from the EUT, the signals from the EUT must be received by the companion device with much higher power (typically > 20 dB) than the power of the interference into the companion device.

In any of the steps in 7.3.1, 7.3.2, 7.3.3, and 7.3.4, the path loss between the EUT and the companion device must be adjusted for reliable communications in the absence of interference. If the EUT fails to communicate reliably during testing, attenuation between the EUT and the companion device may be adjusted as long as the interference levels applied to the EUT are not changed.

The manufacturer shall include, in its test report, a declaration of the relevant monitoring thresholds as well as an explanation of the monitoring and channel selection protocols, including any necessary diagrams. (Note that for the LIC procedure, the requirement “to have monitored all channels” in 47CFR15.323(c)(5) does not include access channels on so-called blind slots, as long as those access channels are not included in the ordered list of LICs. A blind slot is a time slot that the EUT cannot access because it is transmitting or receiving at that time. Additional blind slots are created by the speed of the EUT frequency synthesizer and its ability to change carriers within the guard band between slots.)

The steps in 7.3.1, 7.3.2, 7.3.3, and 7.3.4 apply directly to conductive testing. For radiative testing, the threshold power levels specified below must be translated to the corresponding transmit power levels for the reference antenna, as discussed in Clause 4 and Annex B.

The interference test signals may be either CW or modulated in the same way as the EUT transmission. Adjust the out-of-operating-region interference (if used) to the levels appropriate to the test (i.e., lower threshold, LIC, upper threshold) per 7.2.3 of this standard.

When these tests are performed on an EUT transmitting signaling or control information, transmission on an existing channel (initiated before the interference is applied) may continue for up to 30 s before channel selection is affected by the interference. For such EUTs, it may be necessary to wait 30 s to verify proper monitoring and establish threshold being measured. Similarly, the EUT should continue to transmit on a channel consistent with the interference, which is applied as long as the interference exists.

7.3.1 Lower threshold for EUTs that do not implement the LIC procedure

Choose one of the following two alternative tests:

- a) Set the EUT, by administrative commands, to operate on the carrier closest to the center of the band. By an interference generator, apply interference on that channel at an in-band level at the EUT of $T_L + U_M + 10$ dB. Lower the interference until the EUT can transmit. If the EUT first transmits at an interference level greater than $T_L + U_M$, the EUT fails the test.
- b) By a multicarrier interference generator, apply to the EUT uniform CW interference on all system carriers each at level $T_L + U_M + 10$ dB. Lower the interference uniformly on all carriers until the EUT can transmit. If the EUT first transmits at a per-carrier interference level greater than $T_L + U_M$, the EUT fails the test.

7.3.2 Upper threshold for EUTs that implement the LIC procedure

Choose one of the following two alternative tests:

- a) Set the EUT, by administrative commands, to operate on the carrier closest to the center of the band. By an interference generator, apply interference on that channel at an in-band level at the EUT of $T_U + U_M + 10$ dB. Lower the interference until the EUT can transmit. If the EUT first transmits at an interference level greater than $T_U + U_M$, the EUT fails the test.
- b) By a multicarrier interference generator, apply to the EUT uniform CW interference on all system carriers each at level $T_U + U_M + 10$ dB. Lower the interference uniformly on all carriers until the EUT can transmit. If the EUT first transmits at a per-carrier interference level greater than $T_U + U_M$, the EUT fails the test.

7.3.3 LIC procedure test

A practical implementation of ordering LICs is to group them in bins according to measured signal strength, with generally a maximum difference between individual bin limits chosen to meet the 6 dB resolution requirement of 47CFR15.323(c)(5). With such an implementation, ordering within a bin for the lowest interference is not required, and all channels in a bin are considered equally good. The lowest bin may be the bin for “quiet” channels, and by exception has no lower bin limit, and an upper bin limit that must only be below the calculated lower threshold. “Quiet” channels may be accessed without any LIC ordering; the limit for unordered channels must only be below the lower threshold.

The LIC test procedure is as follows:

- a) Allow EUT transmission on only two carrier frequencies, which will be designated f_1 and f_2 . This limitation to carriers f_1 and f_2 is performed preferably by administration commands for the EUT, or alternatively by applying by a multicarrier interference generator uniform interference on all system carriers except f_1 and f_2 , at a level of $T_U + U_M$, in-band per carrier.
- b) Apply interference to the EUT on f_1 at a level of $T_L + U_M + 7$ dB and on f_2 at a level of $T_L + U_M$. Initiate transmission. The EUT should transmit on f_2 . Terminate the connection. Repeat five times. If the EUT transmits once on f_1 , the test failed.
- c) Apply interference to the EUT on f_1 at a level of $T_L + U_M$ and on f_2 at a level of $T_L + U_M + 7$ dB. Initiate transmission. The EUT should transmit on f_1 . Terminate the connection. Repeat five times. If the EUT transmits once on f_2 , the test failed.
- d) Apply interference to the EUT on f_1 at a level of $T_L + U_M + 1$ dB and on f_2 at a level of $T_L + U_M - 6$ dB. Initiate transmission. If the EUT transmits on f_2 , terminate the connection. Repeat five times. If the EUT transmits once on f_1 , the test failed.
- e) Apply interference to the EUT on f_1 at a level of $T_L + U_M - 6$ dB and on f_2 at a level of $T_L + U_M + 1$ dB. Initiate transmission. If the EUT transmits on f_1 , terminate the connection. Repeat five times. If the EUT transmits once on f_2 , the test failed.

7.3.4 Selected channel confirmation¹⁷

Some types of EUTs may prescan available channels and store the detected power levels in memory to facilitate fast selection of a channel when access is required. Since some amount of time is required for a complete scan,¹⁸ the stored power level for a selected channel may have “aged” since the measurement was taken. The EUT is therefore required to remonitor the selected channel immediately prior to transmission.

¹⁷ See 47CFR15.323(c)(1) and 47CFR15.323(c)(5).

¹⁸ Up to 10 s is allowed for devices operating under 47CFR15.323(c)(5).

The test described as follows is intended to verify that the EUT makes its channel selection decision on the basis of a recent power level reading:

- a) Allow EUT transmission on only two carrier frequencies, which will be designated f_1 and f_2 . This limitation to carriers f_1 and f_2 is performed preferably by administration commands for the EUT, or alternatively by applying by a multicarrier interference generator uniform interference on all system carriers except f_1 and f_2 , at a level of $T_U + U_M$, in-band per carrier. Set the interference level to the EUT on f_1 to a level of $T_U + U_M$, and let there be no interference applied on f_2 .
- b) Initiate transmission and verify that the EUT transmits on f_2 . If a connection was made, terminate it.
- c) Apply interference on f_2 at a level of $T_U + U_M$, in-band, and immediately remove all interference from f_1 and immediately (but not sooner than 20 ms after the interference on f_2 is applied) cause the EUT to attempt transmission. The EUT should now transmit on f_1 , if it transmits.
- d) If the EUT transmits on f_2 , it fails.

7.4 Threshold monitoring bandwidth

If the monitoring is made through the radio receiver used by the EUT for communication, the intended bandwidth requirement on the monitoring system is met. The manufacturer shall declare and provide proper evidence that the monitoring is made through the radio receiver used for communication.

If a dedicated monitoring receiver is used, monitoring bandwidth tests are required. See the test procedures in 7.4.1 and 7.4.2.

Using either frequency administration commands or out-of-operating-region interference (using the procedures in 7.2.3), restrict operation of the EUT to a single carrier frequency f_1 , and verify that the EUT can establish a connection.

When a companion device is required, see 7.3 for set-up guidance.

7.4.1 Simple compliance test

This test may be used to verify that the EUT complies with the rules. While it verifies compliance using a simple test, failure does not indicate that the EUT fails to comply with the rules. If this test fails, the more complex test of 7.4.2 may be used to demonstrate conformance to the requirements of 47CFR15.

Using either frequency administration commands or out-of-operating-region interference (using the procedures in 7.2.3), restrict operation of the EUT to a single carrier frequency f_1 , and verify that the EUT can establish a connection with no interference applied on f_1 . Turn on the interfering signal centered at a frequency above the center of the emission of the EUT separated by 30% of the emission bandwidth of the EUT and with a level 10 dB + U_M above T_U or T_L , as appropriate for EUTs that do or do not meet the requirements for using the upper threshold.¹⁹ The bandwidth of the interfering signal must be equal to or greater than $B_{\text{limit}L}$. Verify that the EUT will not transmit. Repeat with the interference centered at a frequency below the center of the emission of the EUT separated by 30% of the emission bandwidth of the EUT and with a level 10 dB + U_M above T_U or T_L as appropriate for EUTs that do or do not meet the requirements for using the upper threshold. Verify that the EUT will not transmit.

¹⁹ The calculated upper threshold limit shall be used if the EUT system has more than 40 channels and implements the LIC. Otherwise, the calculated lower threshold limit shall be used.

7.4.2 More detailed test

The following (more detailed) test verifies the operation of the EUT by probing the shape of the emissions and the monitoring filter.

From the measurement of the emission bandwidth (see 6.1.5), find the two frequency pairs above and below the frequency of the maximum level of the modulated carrier, most removed from each other, where the signal levels are 6 dB and 12 dB below the peak level of the modulated carrier. With an unmodulated interfering signal set at each of these frequencies and set at a level 6 dB and 12 dB above $T_U + U_M$ or $T_L + U_M$ as appropriate for EUTs that do or do not meet the requirements for using the upper threshold. Verify that the EUT will not transmit. Table 10 summarizes these test frequencies and levels.

Table 10—Test frequencies and levels for monitoring filter test

Test frequency	Test level (above $T_U + U_M$ or $T_L + U_M$, as appropriate)
-6 dB points	6 dB
-12 dB points	12 dB

Note that the test at the center frequency is equivalent to part of the test of 7.3.

7.5 Reaction time and monitoring interval²⁰

The reaction time is the minimum duration of the interference present during the monitoring interval that must be detected by the EUT so as to determine that the monitored time and spectrum window is occupied. The objective of the test is thus to demonstrate that the EUT defers use of a channel when the interfering signals are at least of a time duration that exceeds the allowed limit. An example radiated arrangement of the test equipment is shown in Figure 10. A similar conducted arrangement could be used. The gate device may be a controlled amplifier that is used to pulse the channel interference to provide pulses of the required time duration and position. Such a test requires that the interference be positioned within a defined monitoring interval synchronized to the frame timing of the EUT, and so a derived frame synchronization signal is acquired from the monitoring EUT and applied to the pulse generator. An alternative arrangement would be to connect the output of the pulse generator directly to the “pulse modulation” input of the channel interference generator, if it is so equipped.

The test procedure is as follows:

- a) Using either frequency administration commands or out-of-operating-region interference (using the procedures in 7.2.3), restrict operation of the EUT to a single transmit carrier frequency f_1 , and verify that the EUT can establish a connection with no interference applied on f_1 .
- b) Apply time-synchronized, pulsed interference on f_1 at the pulsed level $T_U + U_M$ or $T_L + U_M$ as appropriate for EUTs that do or do not meet the requirements for using the upper threshold. For a system with 10 ms frame time and N timeslots per frame, the channel interference should be pulsed with N pulses in a 10 ms repetition period (the accuracy of the repetition rate to be ± 10 ppm or better) with a common variable pulse width. The rise and fall times of the interference bursts shall be less than 1 μ s from the 10% to 90% of the final amplitude. The interference pulse shall be of constant amplitude during its burst ($\pm 5\%$). EUTs that divide the use of the channel in time into a number of timeslots ($N \neq 1$) may find it necessary for the pulsed interference to be

²⁰ See 47CFR15.323(c)(1), 47CFR15.323(c)(5), and 47CFR15.323 (c)(7).

synchronized with the timeslot pattern in the frame of the EUT. If necessary, the manufacturer shall supply means by which to synchronize the interference with the timeslot structure of the EUT. The interference shall be timed so as to occur centered within the timeslot.

NOTE—A “timeslot” here refers to a subdivision of the EUT frame interval to support multiple users on a single-carrier frequency using TDMA. It does *not* refer to the subdivision of a 10 ms interval into multiple frames. For example, assume that the duration of the EUT frame is $10/X$ ms, where X is an integer, and each frame is divided into N timeslots. For the test, there should be N interference pulses per 10 ms interval, *not* NX pulses. The timing of the pulses should be arranged such that each of the N timeslots receives one pulse in 10 ms, *not* one pulse per EUT frame, unless the EUT frame duration is 10 ms.²¹

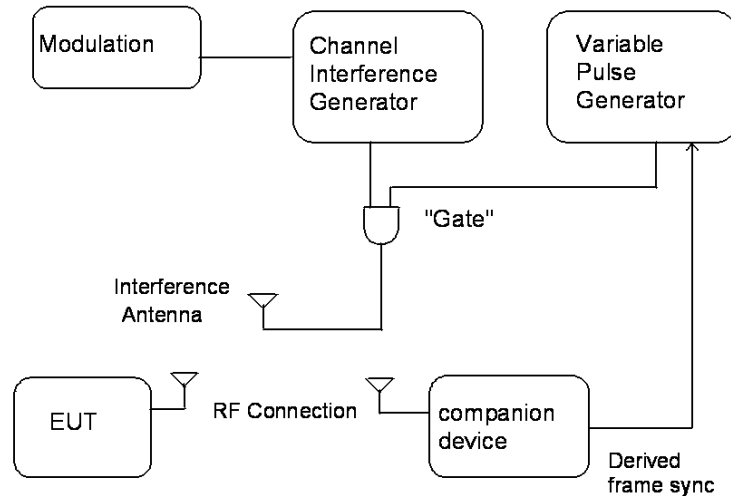

Figure 10—Example arrangement for testing of monitoring reaction time

- c) With the channel interference pulse level at $T_U + U_M$ or $T_L + U_M$ as appropriate for EUTs that do or do not meet the requirements for using the upper threshold, verify that the EUT does not establish a connection when the width of the interference pulse exceeds the largest of $50 \mu\text{s}$ and $50 \sqrt{1.25/B} \mu\text{s}$, where B is the emission bandwidth of the EUT in megahertz.
- d) With the channel interference level 6 dB above $T_U + U_M$ or $T_L + U_M$ as appropriate for EUTs that do or do not meet the requirements for using the upper threshold, verify that the EUT does not establish a connection when the width of the interference pulse exceeds the largest of $35 \mu\text{s}$ and $35 \sqrt{1.25/B} \mu\text{s}$, where B is the emission bandwidth of the EUT in megahertz.

8. Time and spectrum window access procedure

This clause contains tests to verify transmission termination for EUTs that transmit unacknowledged control and signaling information, and tests for EUTs that do not transmit unacknowledged control and signaling information. These tests are intended to verify the proper implementation by the EUT of the requirements of 47CFR15.323(c)(4) to terminate an unacknowledged communications channel within 1 s if no acknowledgement occurs at initiation, or in 30 s if acknowledgements are lost after initiation, and to verify (if the EUT transmits a control and signaling channel) the proper implementation by the EUT of the

²¹ Notes in text, tables, and figures of a standard are given for information only and do not contain requirements needed to implement this standard.

requirement of 47CFR15.323(c)(4) that the control and signaling channel be tested against the access criteria at least every 30 s.

An EUT may transmit a control and signaling channel only, or a communications channel only (see the definitions in 3.1), both types of channel at once, or each at different times. An EUT's physical time and spectrum window may change from transmitting a control and signaling channel to transmitting a communications channel, or vice versa, during the operation of a system incorporating the EUT.

Executing the test procedures may require that the manufacturer provide information to identify those transmissions that correspond to a control and signaling channel and those transmissions that correspond to a communications channel, as the spectrum etiquette requirements for acknowledgements during continued transmission differ. If the EUT may use the same physical time and spectrum window for a control and signaling channel and for a communications channel, the manufacturer shall provide means for determining which type of channel is present.

8.1 Timing for EUTs using control and signaling channel-type transmissions²²

The tests of 8.1.1, 8.1.2, and 8.1.3 are applicable for an EUT capable of transmitting control and signaling information (beacons) on its own when no companion device(s) is present, and are to be made under unacknowledged transmissions conditions.

Note that an EUT that transmits a control and signaling channel must pass the test of 8.1.1 and must pass either the tests of 8.1.2 or the tests of 8.1.3.

8.1.1 Access criteria test interval

This test is for an EUT transmitting control and signaling channels, and validates that the EUT tests the access conditions at least as often as once every 30 s when no acknowledgement is provided for control and signaling channel transmissions.

The test procedure is as follows:

- a) Use frequency administration commands or out-of-operating-region interference (using the procedures in 7.2.3) to restrict operation of the EUT to a single carrier designated f_1 . If the EUT communications protocol uses TDMA to provide multiple channels per carrier, it may be necessary for test-result observability to additionally use frequency administration commands or out-of-operating-region interference to further restrict EUT transmissions to a single timeslot of the usable timeslots available in the TDMA frame structure. If necessary, the manufacturer shall supply means by which to synchronize the interference with the timeslot structure of the EUT. The interference shall be timed so as to occur centered within the timeslot.
- b) Activate the EUT. The EUT, if it transmits, must do so on f_1 , and if the EUT is a TDMA device, it must additionally do so on the unblocked timeslot, if timeslot blocking is used. The EUT must terminate or pause in its repetitive transmission of the control and signaling channel on the open channel to repeat the access criteria not less frequently than every 30 s. If the channel in use for transmissions meets the access criteria, the transmission may start again on the same channel after the access criteria test. Measure the interval between access criteria tests. Repeat this measurement five times. If the EUT fails to repeat the access criteria test at intervals of 30 s or less each time, the EUT fails the test.

²² See 47CFR15.323 (e)(4) and 47CFR15.323(e)(6).

8.1.2 Access criteria functional test (47CFR15.323(c)(6) option not implemented)

This test is to verify that transmission restarts on a different access channel if the access criteria are not met again on the old channel, for EUTs that transmit control and signaling channels and that do not use the provisions of 47CFR15.323(c)(6).

The test procedure is as follows:

- a) Use frequency administration commands or out-of-operating-region interference (using the procedures in 7.2.3) to restrict operation of the EUT to two carriers designated f_1 and f_2 . If the EUT communications protocol uses TDMA to provide multiple channels per carrier, it may be necessary for test-result observability to additionally use frequency administration commands or out-of-operating-region interference to further restrict EUT transmissions to a single timeslot of the usable timeslots available in the TDMA frame structure. If necessary, the manufacturer shall supply means by which to synchronize the interference with the timeslot structure of the EUT. The interference shall be timed so as to occur centered within the timeslot.
- b) Activate the EUT. The EUT, if it transmits, must do so on one of the two open channels. Note the channel used. Apply interference on the channel used by the EUT at the level $T_U + U_M$ or $T_L + U_M$ as appropriate for EUTs that do or do not meet the requirements for using the upper threshold. Verify that after the next pause, the next EUT transmission occurs on the other open channel.

8.1.3 Access criteria functional test (47CFR15.323(c)(6) option implemented)

This test is for EUTs that transmit control and signaling channels and that use the provisions of 47CFR15.323(c)(6), thus to verify that the EUT (if in deferral) waits for a channel to go clear, then implements a 10 ms to 150 ms holdoff prior to using the channel.

The test procedure is as follows:

- a) Use frequency administration commands or out-of-operating-region interference (using the procedures in 7.2.3) to restrict operation of the EUT to a single carrier designated f_1 . If the EUT communications protocol uses TDMA to provide multiple channels per carrier, it may be necessary for test-result observability to additionally use frequency administration commands or out-of-operating-region interference to further restrict EUT transmissions to a single timeslot of the usable timeslots available in the TDMA frame structure. If necessary, the manufacturer shall supply means by which to synchronize the interference with the timeslot structure of the EUT. The interference shall be timed so as to occur centered within the timeslot.
- b) Activate the EUT with no interference present. The EUT must transmit on f_1 . Then apply CW interference on f_1 . The interference level shall be at $T_U + U_M$ or $T_L + U_M$ as appropriate for EUTs that do or do not meet the requirements for using the upper threshold. The EUT must stop transmitting within 30 s.
- c) Cancel the interference. Measure the time interval between the end of the interference transmission and the beginning of transmission by the EUT.
- d) Repeat step b) and step c) 100 times. If each of the time intervals measured is equal to or greater than 10 ms and less than or equal to 150 ms and the measured time intervals vary uniformly between 10 ms and 150 ms, the EUT passes the test.

8.2 Timing for EUTs using communications channel-type transmissions

This group of tests is applicable for an EUT that implements communications channel transmissions. The tests are intended to verify the timing of the EUT under conditions where acknowledged transmissions are expected. Acknowledged transmissions require a companion device; see Figure 7 or Figure 8 for test configuration.

8.2.1 Acknowledgements²³

This subclause tests the EUT response to the lack of initial or continuing acknowledgements from the companion device under conditions where acknowledged transmissions are expected.

For the purposes of this test, the companion device or its interconnection shall be controllable²⁴ so that acknowledgements to the EUT of EUT transmissions may be blocked. If a beacon signal from the companion device is necessary for the EUT to attempt the start of a communications channel, the EUT shall be provided with the beacon from the companion device.

The test procedure of step a) in this subclause verifies that a starting EUT will cease transmission within 1 s if an initial acknowledgement from a companion device is not received during the establishment of a communications channel. The test procedure of step c) in this subclause verifies that an EUT will cease transmission on the communications channel if an acknowledgement is not received at least every 30 s, for an established communications channel.

Starting the activation of a communications channel in this context means sending the first message(s) on the selected communications channel. For the test procedure of step a) in this subclause, the EUT is the starting device. For the test procedure of step c) in this subclause, either the EUT or the companion device may be the starting device, as appropriate.

The test procedure is as follows:

- a) This step applies only to an EUT that can start the activation of the communications channel. Block acknowledgements from the companion device. Have the EUT start transmission on the communications channel. Verify that the EUT does not transmit on the communications channel for more than 1 s, since an initial acknowledgement is not received.
- b) Unblock acknowledgements from the companion device, and verify that the EUT can initiate and maintain a communications channel when acknowledgements are present.
- c) This step tests that an EUT terminates transmissions on the communications channel within 30 s if acknowledgements cease, for an established communications channel. This test applies for both an EUT that starts the activation and an EUT that only responds. Activate the communications channel transmissions with unblocked acknowledgements between the EUT and the companion device. Then block acknowledgements from the companion device and verify that the EUT terminates its transmission on the communication channel in 30 s or less.

²³ See 47CFR15.323(c)(4).

²⁴ For the purpose of testing the response of the EUT to the lack of initial or continuing acknowledgements, the acknowledgement by the companion device of EUT transmissions may be prevented by turning off the companion device, by the insertion of attenuation between the companion device and the EUT, by the application of blocking interference to the companion device, by administrative commands applied to the companion device, or by any means appropriate to the purpose of the test.

8.2.2 Transmission duration²⁵

This subclause tests the EUT for compliance to the requirement of 47CFR15.323(c)(3) that the EUT does not continue to use the same channel without executing the access criteria at least as often as every 8 h.

The test procedure is as follows:

- a) Activate the EUT and initiate a communication channel with the companion device, and start a timer or frame counter.
- b) Stop the timer at the end of the EUT transmission on the current time and frequency window.

The EUT fails if the timer is greater than the limit. For an EUT with a frame period of 10/X ms, no more than 2 880 000 X frames²⁶ should be transmitted without a break.

8.3 Duplex connections²⁷

This test verifies that the two devices communicating over a duplex connection comply with the access criteria. Subclause 8.3 is required for and applies only to EUTs that are designated as “initiating” and “responding” devices, and together satisfy the criteria of 47CFR15.323(c)(10).²⁸ The manufacturer shall state whether the criteria of 47CFR15.323(c)(10) are used, and if so, which EUTs are initiating devices and which devices are responding devices, and shall provide, as part of the test report, appropriate diagrams and other material to explain procedures for making duplex connections.

The initiating device is the EUT, and the responding device is the companion device tested in conjunction with the EUT.

To comply with 47CFR15.323(c)(10), the EUT must monitor both its transmit time/spectrum window and its receive time/spectrum window. The test therefore requires that interference at the EUT on its transmit and receive time/spectrum windows are varied independently. Figure 11 gives an illustrative example of the interference, as seen at the EUT. Figure 11(a) represents the interference pattern to a TDMA EUT using time-division duplexing (TDD) on a single RF carrier and eight duplex time slots per carrier. Figure 11(b) shows the interference to a frequency-division multiple access (FDMA) EUT using TDD with a single duplex channel per carrier and eight carriers.

Note that in both the TDMA and FDMA cases, the transmit and receive time and spectrum windows have different power levels at the EUT. Further, a transmit time and spectrum window may be interference-free while its paired receive window is not. In the example shown, the power levels of the receive windows are 7 dB higher than those of the transmit windows; in each case, one transmit window and one receive window is interference-free, but the interference-free transmit and receive windows do not constitute a duplex pair. In the TDMA example of Figure 11(a), transmit slot 6 and receive slot 2 are interference-free, and in the FDMA example of Figure 11(b), the transmit slot on frequency 3 and the receive slot on frequency 6 are interference-free. Producing these interference patterns requires interference generators that can be synchronized to the frame clock of the EUT and can generate bursts of interference equal to the duration of the EUT transmit/receive bursts.

²⁵ See 47CFR15.323(c)(3).

²⁶ $(3\ 600\ \text{s/h})(8\ \text{h})/(10/X\ \text{ms/frame}) = 2\ 880\ 000$.

²⁷ See 47CFR15.323(c)(10)

²⁸ See 47CFR15.323(c)(10), which specifies that for the initiating device “both the intended transmit and receive time and spectrum windows [must] meet the access criteria.” This is interpreted to mean, in the case of LIC operation per 15.323(c)(5), that the greatest of the monitored level on the transmit and receive time/spectrum windows is used to determine the least interfered time/spectrum window duplex pair.

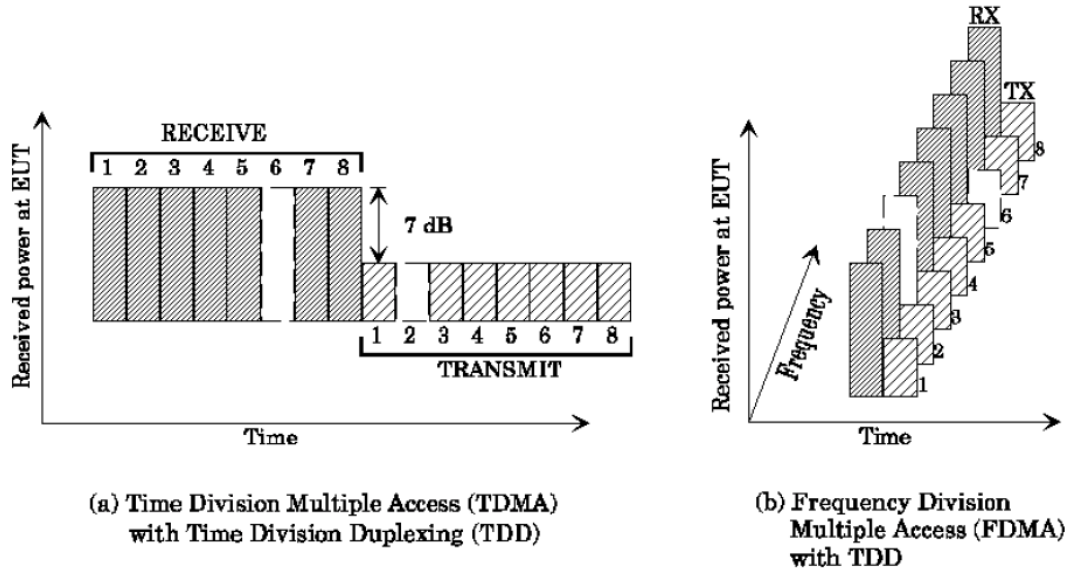

Figure 11—Examples of interference for duplex connection test

If no system clock signal is available to synchronize the interference generators to the system’s frame timing, establish a connection and use the start of the initiating device’s transmit burst as the synchronization signal (the transceiver pair used to generate the sync signal must be electromagnetically isolated from the EUT and the companion device). For an FDMA/TDD system, this procedure will provide frame synchronization. For a TDMA/TDD system, it will provide slot synchronization, but the transmit burst can occur on any slot in the transmit portion of the initiating device’s frame. Thus, it is possible that both interference-free slots from the generators could occur in either the transmit or receive portion of the EUT’s frame. However, the steps in 8.3.1 and 8.3.2 still apply because the initiating device must monitor both transmit and receive time/spectrum windows. The success criterion remains that the duplex slot pair is selected on which the interference power on the “interfered” half of the connection (transmit or receive) is either below $T_L + U_M$ (for systems that do not meet the criterion for using the upper threshold) or is a minimum (for systems that meet the criterion for using the upper threshold). For example, in Figure 11(a), the slot pair labeled “6” should be selected. In Figure 11(b), the frequency pair labeled “3” should be selected.

The same approach can be applied to systems that use frequency duplexing.²⁹ For completeness, Figure 12 gives an illustrative example of the interference for an FDMA system using frequency duplexing.

Note that an EUT may pass either the tests of 8.3.1 or the tests of 8.3.2.

8.3.1 Validation of dual access criteria check for EUTs that do not implement the upper threshold

This test validates proper operation of an EUT that operates according to the provisions of 47CFR15.323(c)(10) using a check of both transmit and receive channels on one end of the link to qualify both ends of the link for transmissions. If an EUT operates as part of a system that incorporates more than one kind of initiating device or more than one kind of responding device, then this test will be performed on each type of initiating device, with each type of responding device.

²⁹ It is expected that most systems in the 1920 MHz to 1930 MHz band will use TDD, because of the need for frequency-duplexed systems to maintain some frequency separation between the transmit and receive bands. Moreover, the requirement that a device monitor its own transmit time/spectrum window would tend to make implementation of a conventional frequency-duplexed system awkward.

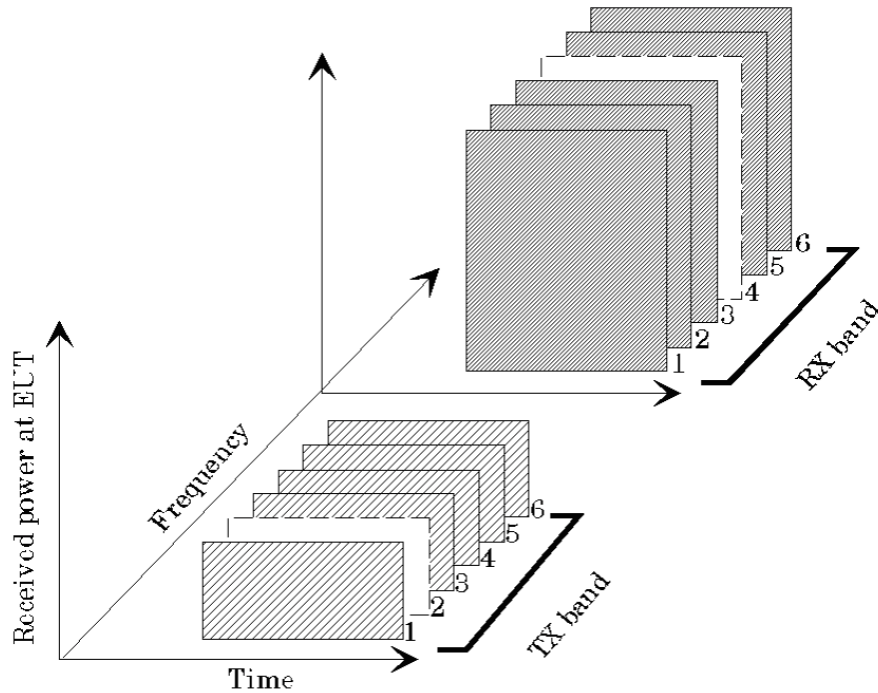

Figure 12—Example of duplex interference for FDMA frequency-duplexed system

The test procedure is as follows:

- a) Adjust the path loss between the EUT and its companion device such that the received signal to the EUT from the companion device is at least 40 dB above $T_L + U_M$.
- b) By using either frequency administration commands or out-of-operating-region interference applied to the EUT, restrict the EUT and its companion device to operation at a single carrier f_1 for TDMA systems and on f_1 and f_2 and corresponding duplex carriers for FDMA systems. If out-of-operating-region interference is used to confine the EUT to the intended carrier(s), use the procedures of 7.2.3 to ensure that the out-of-operating-region interference does not corrupt the test results. Verify that the EUT and its companion device can establish a connection on a time and spectrum window on the intended carrier(s). Terminate the connection.
- c) Apply interference at $T_L + U_M$ per carrier to the EUT on the enabled carrier(s) on all of its *receive* time/spectrum windows except one, which has interference at least 10 dB below T_L . Apply interference at $T_L + U_M$ to the EUT on all *transmit* time/spectrum windows on the enabled carrier(s). Ensure that the interference levels at the companion device are at least 10 dB below T_L for all time/spectrum windows.
- d) Cause the EUT to attempt to establish a connection. If a connection is established, the test fails.
- e) If a connection exists, terminate it. Apply interference at $T_L + U_M$ to the EUT on the enabled carrier(s) on all of its *transmit* time/spectrum windows except one, which has interference at least 10 dB below T_L . Apply interference at $T_L + U_M$ to the EUT on all *receive* time/spectrum windows on the enabled carrier(s). Ensure that the interference level at the companion device is at least 10 dB below T_L for all time/spectrum windows.
- f) Cause the EUT to attempt to establish a connection. If a connection is established, the test fails.

8.3.2 Validation of dual access criteria check for EUTs that implement the upper threshold

The test procedure is as follows:

- a) Adjust the path loss between the EUT and its companion device such that the received signal to the EUT from the companion device is at least 40 dB above $T_L + U_M$.
- b) By using either frequency administration commands or out-of-operating-region interference applied to the EUT, restrict the EUT and its companion device to operation at a single carrier f_1 for TDMA systems and on f_1 and f_2 and corresponding duplex carriers for FDMA systems. If out-of-operating-region interference is used to confine the EUT to the enabled carrier(s), use the procedures of 7.2.3 to ensure that the out-of-operating-region interference does not corrupt the test results. Verify that the EUT and its companion device can establish a connection on a time/spectrum window on the enabled carrier(s). Terminate the connection.
- c) Apply interference to the EUT on the EUT's *transmit* time/spectrum windows at $T_L + U_M$ per carrier on all time/spectrum windows except for one, which has interference at least 10 dB below T_L . Adjust the interference to the EUT on its *receive* time/spectrum windows such that a single time/spectrum window has interference at least 10 dB below T_L , and the interference on the other time/spectrum windows is at $T_L + U_M + 7$ dB. The interference to the companion device should be at least 10 dB below T_L on all active time/spectrum windows. The interference-free *receive* time/spectrum window must not be the duplex mate of the interference-free *transmit* time/spectrum window.³⁰
- d) Cause the EUT to attempt to establish a connection. The connection should be made on the interference-free *receive* time/spectrum window and its duplex mate. Otherwise, the EUT fails the test.
- e) If a connection exists, terminate it. Reduce the interference on the EUT's *receive* time/spectrum windows to a level of $T_L + U_M$ per carrier on all time/spectrum windows except for one, which has interference at least 10 dB below T_L . Raise the interference on the EUT's *transmit* time/spectrum windows to a level of $T_L + U_M + 7$ dB, maintaining one time/spectrum window with interference at least 10 dB below T_L . The interference to the companion device should be at least 10 dB below T_L on all active time/spectrum windows. Again, the interference-free *transmit* and *receive* time/spectrum windows should not constitute a duplex pair if the system designates a specific duplex pairing for time/spectrum windows.
- f) Cause the EUT to attempt to establish a connection. The connection should be made on the interference-free *transmit* time/spectrum window and its duplex mate. Otherwise, the system fails the test.
- g) Terminate the connection and raise the interference to the EUT on all of the EUT's *transmit* and *receive* time/spectrum windows to $T_U + U_M$ per carrier on all time/spectrum windows except for a single *transmit* time/spectrum window and a single *receive* time/spectrum window, which shall have interference at least 10 dB below T_L . The low-interference *transmit* and *receive* time/spectrum windows shall not constitute a duplex pair. Adjust the path loss between the EUT and its companion device such that the received signal to the EUT from the companion device is at least 30 dB above T_U . Cause the EUT to attempt to establish a connection. If the EUT transmits (attempts to establish a connection), or a connection is established, the test fails.

³⁰ This assumes that the system designates a fixed duplex pairing for transmit and receive time/spectrum windows. If this is not the case, the interference-free time/spectrum windows must be selected by the EUT for both the transmit and receive directions.

8.4 Alternative monitoring interval³¹

The manufacturer shall state whether the system uses the provisions of 47CFR15.323(c)(10) and 47CFR15.323(c)(11) and, if so, which EUTs are the “initiating devices” and which devices use the provisions of 47CFR15.323(c)(11), and the manufacturer shall provide, in the test report, the appropriate diagrams and other material to explain the use of the provisions of 47CFR15.323(c)(11). This test will be performed on each type of initiating device that uses the provisions of 47CFR15.323(c)(11). The EUT is the initiating device. The companion device is the “responding device.” Each type of initiating device must be tested with each type of responding device.

This test validates the ability of the EUT to distinguish between same-system and other-system interference for purposes of satisfying the requirement of 47CFR15.323(c)(11).

The test procedure is as follows:

- a) Adjust the path loss between the EUT and its companion device such that the received signal to the EUT from the companion device is at least 30 dB above T_L .
- b) By using either frequency administration commands or out-of-operating-region interference applied to the EUT, restrict the EUT and its companion device to operation at a single carrier f_1 for TDMA systems and on f_1 and f_2 and corresponding duplex carriers for FDMA systems. If out-of-operating-region interference is used to confine the EUT to the intended carriers, use the procedures of 7.2.3 to ensure that the residual interference power from the out-of-operating-region interference generator(s) does not corrupt the test results. Verify that the EUT and its companion device can establish a connection.
- c) Apply interference at $T_U + U_M$ per carrier to the EUT on all *transmit* time/spectrum windows on the enabled carrier(s). The interference must use the same physical layer parameters (modulation, frame format, etc.) as the EUT transmissions, but with a system identifier different from that used by the EUT and the companion device. Ensure that the interference level at the companion device is at least 10 dB below T_L . Apply no interference to the *receive* time/spectrum windows on the enabled carriers.
- d) Cause the EUT to attempt to establish a connection. If a connection is established, the test fails.

9. Test report

Test reports are the means of presenting the test results to the appropriate procuring or regulatory agency or for archiving the data in the files of the testing organization. As such, test reports shall be clearly written, in unambiguous language.

9.1 Test report contents

The conditions of test given in Clause 6, Clause 7, and Clause 8 shall be described in the test report in order for the test results to be properly documented.

9.2 Applicable standards

In addition to this standard, any standards to which the EUT was tested shall be clearly stated in the test report. Where referenced standards have more than one measurement procedure, or where the referenced

³¹ See 47CFR15.323(c)(11).

measurement procedure has options, the test report shall state which procedures or options were used. The test report shall also state the issue or year of the referenced standard(s) used.

9.3 Equipment units tested

The test report shall list all equipment tested, including product type and marketing designations where applicable. Serial numbers and any other distinguishing identification features shall also be included in the test report. Identification or detailed description shall also be made of interconnecting cables. The rationale for selecting the EUT (comprised of the equipment units needed to be functionally complete and the necessary cabling) shall be noted in the test report.

9.4 Test configuration

The setups of the equipment and cable or wire placement on the test site that produce the highest radiated and the highest ac powerline and antenna terminal conducted emissions (if applicable) shall be clearly shown and described. Drawings or photographs may be used for this purpose. A block diagram showing the interconnection of the major functional units is also useful.

9.5 List of test equipment

A complete list of all test instrumentation used shall be included with the test report. Manufacturer's model and serial numbers, and date of last calibration and calibration interval, shall be included. Measurement cable loss, external RF attenuators used, measuring instrument bandwidth and detector function, video bandwidth, if appropriate, and antenna factors shall also be included where applicable.

9.6 Units of measurement

Measurements of conducted emissions shall be reported in units of decibels referenced to 1 mW (dBm). Measurements of operating frequency, operating frequency with variations in ambient temperature and input mains or battery voltage, and occupied bandwidth of intentional radiators shall be reported in units of hertz or multiples thereof [e.g., kilohertz, megahertz]. Measurements of input RF power to intentional radiators shall be reported in units of watts. All formulas of conversions and conversion factors, if used, shall be included in the measurement report.

9.7 Location of test site

The location of the test site and accreditation expiry date (if applicable) shall be identified in the test report. Sites that have received recognition from various accreditation bodies shall use the same site address information as was included in their original application for recognition.

9.8 Measurement procedures

The sequence of testing followed to determine the data included in the test report should be documented.

9.9 Reporting measurement data

The measurement results along with the appropriate limits for comparison shall be presented in tabular or graphical form. Alternatively, recorded charts or photographs of a receiver or spectrum analyzer display or other self-displaying instrumentation may be used if the information is clearly presented showing comparison to the limits and all data conversion is explained. The method of comparing measured data output to the limits shall be included.

9.10 General and special conditions

If an alternate test method was used, the test report shall identify and describe that method, provide justification for its use, and describe how the results obtained through its use correlate with the methods specified by the standard to which the EUT was tested. Instrumentation, instrument attenuator and bandwidth settings, detector function, EUT arrangement, and all other pertinent details of the test shall be provided so that the alternate test method can be replicated. When automatic scan techniques were used, an explanation of how the highest emission relative to the limit from the EUT was determined and the scan rate used to obtain recorded emissions is to be included in the test report. The actual operating and environmental conditions (e.g., voltage, powerline frequency, temperature, relative humidity, etc.) shall be listed in the report.

9.11 Summary of results

The test report summary section shall indicate whether the EUT passes or fails, and give margins (where applicable) with respect to the limits to which it was tested. If the equipment passes only with specific modifications or special attributes (such as shielded cables), this information shall be included in the summary results.

9.12 Required signatures

The test report shall contain the signature of the representative of the organization performing the tests. In addition, the test report shall identify the staff responsible for the proper execution of the test, and the name and address of the party requesting the tests. If changes are made during the period of test to bring the EUT into compliance, the test report shall so indicate. In addition, the report submitted to the procuring organization or regulatory agency shall include a signed statement by the manufacturer or developer agreeing to the changes and their incorporation into production.

9.13 Test report appendixes

The test report shall contain, if required, photographs or detailed sketches of the EUT configuration, showing sufficient information to allow the EUT to be reconfigured in a manner that would allow the original test to be replicated with a high likelihood that the test results would be in agreement with the results of the original test within acceptable tolerances.

9.14 Test report disposition

The test report shall be maintained by the testing organization for a period of at least three years following the date of the test. The manufacturer may be required by a regulatory agency to maintain a copy of the report for a longer period of time.

Annex A

(informative)

47CFR15, Subpart D—Rules and test cases for UPCS devices

47CFR15, Subpart D—Unlicensed PCS Devices, as of December 29 2004		ANSI test
Scope	15.301 This subpart sets out the regulations for unlicensed personal communications services (PCS) devices operating in the 1910–1930 MHz frequency band.	Information
Definition	15.303	
Emission bandwidth	15.303(c) emission bandwidth: For purposes of this subpart, the emission bandwidth shall be determined by measuring the width of the signal between two points, one below the carrier center frequency and one above the carrier center frequency, that are 26 dB down relative to the maximum level of the modulated carrier. Compliance with the emissions limits is based on the use of measurement instrumentation employing a peak detector function with an instrument resolutions bandwidth approximately equal to 1.0 percent of the emission bandwidth of the EUT under measurement.	6.1.3
Peak transmit power	15.303(f) peak transmit power: The peak power output as measured over an interval of time equal to the frame rate or transmission burst of the EUT under all conditions of modulation. Usually this parameter is measured as a conducted emission by direct connection of a calibrated test instrument to the equipment under test. If the EUT cannot be connected directly, alternative techniques acceptable to the Commission may be used.	6.1.2
PCS devices	15.303(g) personal communications service (PCS) devices [unlicensed]: Intentional radiators operating in the frequency band 1920–1930 MHz that provide a wide array of mobile and ancillary fixed communication services to individuals and businesses.	Definition
Spectrum window	15.303(h) spectrum window: An amount of spectrum equal to the intended emission bandwidth in which operation is desired.	Definition
Thermal noise power	15.303(j) thermal noise power: The noise power in watts defined by the formula $N = kTB$, where N is the noise power in watts, k is Boltzmann's constant, T is the absolute temperature in degrees Kelvin (e.g., 295 K), and B is the emission bandwidth of the EUT in hertz.	Definition
Time window	15.303(k) time window: An interval of time in which transmission is desired.	Definition

47CFR15, Subpart D—Unlicensed PCS Devices, as of December 29 2004		ANSI test
Equipment authorization	<p>15.305</p> <p>Equipment authorization requirement.</p> <p>UPCS devices operating under this subpart shall be certificated by the Commission under the procedures in Subpart J of Part 2 of this Chapter before marketing. The application for certification must contain sufficient information to demonstrate compliance with the requirements of this subpart.</p>	Information
Coordination	<p>15.307</p> <p>Coordination with fixed microwave service.</p>	UTAM test
UTAM Role	<p>15.307(a)</p> <p>UTAM, Inc., is designated to coordinate and manage the transition of the 1910–1930 MHz band from private operational-fixed microwave service (OFS) operating under Part 94 of this Chapter to unlicensed PCS operations, conditioned upon submittal to and acceptance by the Commission of: (1) a funding plan that is equitable to all prospective manufacturers of unlicensed PCS devices; and (2) a plan for “band clearing” that will permit the implementation of noncoordinatable (nomadic) devices and, in particular, noncoordinatable data PCS devices, as promptly as possible. The responsibilities of UTAM, Inc. include, but are not limited to, relocation of existing OFS microwave stations pursuant to requirements established in ET Docket No. 92-9, negotiating costs of relocation, ensuring that comparable facilities are provided, and resolving any disputes of interference to OFS microwave operations from unlicensed PCS operations. These responsibilities shall terminate upon a determination by the Commission that interference to OFS microwave operations from unlicensed PCS operations is no longer a concern.</p>	UTAM test
UTAM certification	<p>15.307(b)</p> <p>Each application for certification of equipment operating under the provisions of this Subpart must be accompanied by an affidavit from UTAM, Inc. certifying that the applicant is a participating member of UTAM, Inc. In the event a grantee fails to fulfill the obligations attendant to participation in UTAM, Inc., the Commission may invoke administrative sanctions as necessary to preclude continued marketing and installation of devices covered by the grant of certification, including but not limited to revoking certification.</p>	UTAM test
Cross reference	<p>15.309</p> <p>Cross reference</p>	
	<p>15.309(a)</p> <p>The provisions of Subpart A of this Part apply to unlicensed PCS devices, except where specific provisions are contained in Subpart D.</p>	6.1.6
	<p>15.309(b)</p> <p>The requirements of Subpart D apply only to the radio transmitter contained in the UPCS device. Other aspects of the operation of a UPCS device may be subject to requirements contained elsewhere in this Chapter. In particular, a UPCS device that includes digital circuitry not directly associated with the radio transmitter also is subject to the requirements for unintentional radiators in Subpart B.</p>	6.1.6

47CFR15, Subpart D—Unlicensed PCS Devices, as of December 29 2004		ANSI test
Labeling	<p>15.19(a)</p> <p>(3) All other devices shall bear the following statement in a conspicuous location on the device:</p> <p>This device complies with part 15 of the FCC Rules. Operation is subject to the following two conditions: (1) This device may not cause harmful interference, and (2) this device must accept any interference received, including interference that may cause undesired operation.</p> <p>(4) Where a device is constructed in two or more sections connected by wires and marketed together, the statement specified under paragraph (a) of this section is required to be affixed only to the main control unit.</p> <p>(5) When the device is so small or for such use that it is not practicable to place the statement specified under paragraph (a) of this section on it, the information required by this paragraph shall be placed in a prominent location in the instruction manual or pamphlet supplied to the user or, alternatively, shall be placed on the container in which the device is marketed. However, the FCC identifier or the unique identifier, as appropriate, must be displayed on the device.</p>	Labels
Measurement procedures	<p>15.313</p> <p>Measurement procedures.</p> <p>Measurements must be made in accordance with Subpart A, except where specific procedures are specified in Subpart D. If no guidance is provided, the measurement procedure must be in accordance with good engineering practice.</p>	ANSI C63.17 (general)
Conducted limits	<p>15.315</p> <p>Conducted limits.</p> <p>An unlicensed PCS device that is designed to be connected to the public utility (AC) power line must meet the limits specified in 47CFR15.207.</p>	ANSI C63.4- 2003
Antenna requirement	<p>15.317</p> <p>Antenna requirement.</p> <p>An unlicensed PCS device must meet the antenna requirement of 47CFR15.203.</p>	Information
General technical requirements	<p>15.319</p> <p>General technical requirements</p>	
Frequency of operation	<p>15.319(a)</p> <p>[reserved]</p>	
Digital modulation	<p>15.319(b)</p> <p>All transmissions must use only digital modulation techniques.</p>	6.1.4
Peak transmit power	<p>15.319(c)</p> <p>Peak transmit power shall not exceed 100 microwatts multiplied by the square root of the emission bandwidth in hertz. Peak transmit power must be measured over any interval of continuous transmission using instrumentation calibrated in terms of an rms-equivalent voltage. The measurement results shall be properly adjusted for any instrument limitations, such as detector response times, limited RBW capability when compared to the emission bandwidth, sensitivity, etc., so as to obtain a true peak measurement for the emission in question over the full bandwidth of the channel.</p>	6.1.2

ANSI C63.17-2006
Methods of Measurement of the Electromagnetic and Operational Compatibility of UPCS Devices

47CFR15, Subpart D—Unlicensed PCS Devices, as of December 29 2004		ANSI test
Power spectral density	15.319(d) Power spectral density shall not exceed 3 milliwatts in any 3 kHz bandwidth as measured with a spectrum analyzer having an RBW of 3 kHz.	6.1.5
Antenna gain	15.319(e) The peak transmit power shall be reduced by the amount in decibels that the maximum directional gain of the antenna exceeds 3 dBi.	4.3.1
Operational failure requirement	15.319(f) The device shall automatically discontinue transmission in case of either absence of information to transmit or operational failure. These provisions are not intended to preclude transmission of control and signaling information or use of repetitive codes used by certain digital technologies to complete frame or burst intervals.	Declaration with explanation
Spurious emission	15.319(g) Notwithstanding other technical requirements specified in this subpart, attenuation of emissions below the general emission limits in 47CFR15.209 is not required.	6.1.6
Spurious emission transition limits	15.319(h) Where there is a transition between limits, the tighter Information limit shall apply at the transition point.	
Safety exposure levels	15.319(i) Unlicensed PCS devices are subject to the radiofrequency radiation exposure requirements specified in §§1.1307(b), 2.1091 and 2.1093 of this chapter, as appropriate. All equipment shall be considered to operate in a “general population/uncontrolled” environment. Applications for equipment authorization of devices operating under this section must contain a statement confirming compliance with these requirements for both fundamental emissions and unwanted emissions. Technical information showing the basis for this statement must be submitted to the Commission upon request.	Refer to IEEE 1528-2003
UPCS device	15.323 Specific requirements for devices operating in the UPCS band.	
Emission bandwidth and power level	15.323(a) Operation shall be contained within the 1920–1930 MHz band. The emission bandwidth shall be less than 2.5 MHz. The power level shall be as specified in 47CFR15.319(c), but in no event shall the emission bandwidth be less than 50 kHz.	6.1.3 and 6.1.2
Channel packing	15.323(b) [removed and reserved]	
Listen before transmit (LBT)	15.323(c) Isochronous devices must incorporate a mechanism for monitoring the time and spectrum windows that its transmission is intended to occupy.	

47CFR15, Subpart D—Unlicensed PCS Devices, as of December 29 2004		ANSI test
Monitoring time	15.323(c)(1) Immediately prior to initiating transmission, devices must monitor the combined time and spectrum windows in which they intend to transmit for a period of at least 10 milliseconds for systems designed to use a 10 millisecond or shorter frame period or at least 20 milliseconds for systems designed to use a 20 millisecond frame period.	7.3.4
Monitoring threshold	15.323(c)(2) The monitoring threshold must not be more than 30 dB above the thermal noise power for a bandwidth equivalent to the emission bandwidth of the device.	7.3.1
Maximum transmit period	15.323(c)(3) If no signal above the threshold level is detected, transmission may commence and continue with the same emission bandwidth in the monitored time and spectrum windows without further monitoring. However, occupation of the same combined time and spectrum windows by a device or group of cooperating devices continuously over a period of time longer than 8 hours is not permitted without repeating the access criteria.	8.2.2
System acknowledgement	15.323(c)(4) Once access to specific combined time and spectrum windows is obtained an acknowledgement from a system participant must be received by the initiating transmitter within one second or transmission must cease. Periodic acknowledgements must be received at least every 30 seconds or transmission must cease. Channels used exclusively for control and signaling information may transmit continuously for 30 seconds without receiving an acknowledgement, at which time the access criteria must be repeated.	8.1 or 8.2
Least interfered channel (LIC)	15.323(c)(5)	
LIC selection	15.323(c)(5).1 If access to spectrum is not available as determined by the above and a minimum of 40 duplex system access channels are defined for the system, the time and spectrum windows with the lowest power level below a monitoring threshold of 50 dB above the thermal noise power determined for the emission bandwidth may be accessed.	7.3.2 and 7.3.3
LIC confirmation	15.323(c)(5).2 A device utilizing the provisions of this paragraph must have monitored all access channels defined for its system within the last 10 seconds and must verify, within the 20 milliseconds (40 milliseconds for devices designed to use a 20 millisecond frame period) immediately preceding actual channel access, that the detected power of the selected time and spectrum windows is no higher than the previously detected value.	7.3.3 and 7.3.4
Power measurement resolution	15.323(c)(5).3 The power measurement resolution for this comparison must be accurate to within 6 dB.	7.3.3

47CFR15, Subpart D—Unlicensed PCS Devices, as of December 29 2004		ANSI test
Maximum spectrum occupancy	15.323(c)(5).4 No device or group of co-operating devices located within 1 meter of each other shall, during any frame period, occupy more than 6 MHz of aggregate bandwidth, or alternatively, more than one third of the time and spectrum windows defined by the system.	Declaration
Random waiting	15.323(c)(6) If the selected combined time and spectrum windows are unavailable, the device may either select and monitor different windows or seek to use the same windows after waiting an amount of time, randomly chosen from a uniform random distribution between 10 and 150 milliseconds, commencing when the channel becomes available.	8.1.3
Monitoring requirements	15.323(c)(7)	
Monitoring bandwidth	15.323(c)(7).1 The monitoring system bandwidth must be equal to or greater than the emission bandwidth of the intended transmission.	7.4
Monitoring reaction time	15.323(c)(7).2 The monitoring system shall have a maximum reaction time less than $50 \times \text{SQRT}(2.5/\text{emission bandwidth in MHz}) \mu\text{s}$ for signals at the applicable threshold level but shall not be required to be less than 50 μs . If a signal is detected that is 6 dB or more above the applicable threshold level, the maximum reaction time shall be $35 \times \text{SQRT}(2.5/\text{emission bandwidth in MHz}) \mu\text{s}$ but shall not be required to be less than 35 μs .	7.5
Monitoring antenna	15.323(c)(8) The monitoring system shall use the same antenna used for transmission, or an antenna that yields equivalent reception at that location.	Clause 4
Monitoring threshold relaxation	15.323(c)(9) Devices that have a power output lower than the maximum permitted under the rules may increase their monitoring detection threshold by one decibel for each one decibel that the transmitter power is below the maximum permitted.	Clause 4
Duplex system LBT	15.323(c)(10) An initiating device may attempt to establish a duplex connection by monitoring both its intended transmit and receive time and spectrum windows. If both the intended transmit and receive time and spectrum windows meet the access criteria, then the initiating device can initiate a transmission in the intended transmit time and spectrum window. If the power detected by the responding device can be decoded as a duplex connection signal from the initiating device, then the responding device may immediately begin transmitting on the receive time and spectrum window monitored by the initiating device.	8.3

47CFR15, Subpart D—Unlicensed PCS Devices, as of December 29 2004		ANSI test
Co-located device LBT	<p>15.323(c)(11)</p> <p>An initiating device that is prevented from monitoring during its intended transmit window due to monitoring system blocking from the transmissions of a co located (within one meter) transmitter of the same system, may monitor the portions of the time and spectrum windows in which they intend to receive over a period of at least 10 milliseconds. The monitored time and spectrum window must total at least 50 percent of the 10 millisecond frame interval and the monitored spectrum must be within 1.25 MHz of the center frequency of channel(s) already occupied by that device or co located co operating devices. If the access criteria is met for the intended receive time and spectrum window under the above conditions, then transmission in the intended transmit window by the initiating device may commence.</p>	8.4
Fair access	<p>15.323(c)(12)</p> <p>The provisions of (c)(10) or (c)(11) shall not be used to extend the range of spectrum occupied over space or time for the purpose of denying fair access to spectrum to other devices.</p>	Information
Adjacent emissions	15.323(d)	
Out-of-band emissions	<p>15.323(d).1</p> <p>Emissions shall be attenuated below a reference power of 112 milliwatts as follows: 30 dB between the band edge and 1.25 MHz above or below the band; 50 dB between 1.25 and 2.5 MHz above or below the band; and 60 dB at 2.5 MHz or greater above or below the band.</p>	6.1.6
In-band unwanted emissions	<p>15.323(d).2</p> <p>Emissions inside the band must comply with the following emission mask: In the bands between 1B and 2B measured from the center of the emission bandwidth, the total power emitted by the device shall be at least 30 dB below the transmit power permitted for that device; in the bands between 2B and 3B measured from the center of the emission bandwidth, the total power emitted by an intentional radiator shall be at least 50 dB below the transmit power permitted for that radiator; in the bands between 3B and the band edge, the total power emitted by an intentional radiator in the measurement bandwidth shall be at least 60 dB below the transmit power permitted for that radiator. "B" is defined as the emission bandwidth of the device in hertz. Compliance with the emission limits is based on the use of measurement instrumentation employing peak detector function with an instrument resolution bandwidth approximately equal to 1.0 percent of the emission bandwidth of the device under measurement.</p>	6.1.6
Frame Requirement	15.323(e)	
Frame period	<p>15.323(e).1</p> <p>The frame period (a set of consecutive time slots in which the position of each time slot can be identified by reference to a synchronizing source) of an intentional radiator operating in this band shall be 20 milliseconds or 10 milliseconds/X where X is a positive whole number.</p>	6.2.3

47CFR15, Subpart D—Unlicensed PCS Devices, as of December 29 2004		ANSI test
Frame repetition stability	15.323(e).2 Each device that implements time division for the purposes of maintaining a duplex connection on a given frequency carrier shall maintain a frame-repetition rate with a frequency stability of at least 50 parts per millions (ppm).	6.2.2
TDMA repetition stability	15.323(e).3 Each device which further divides access in time in order to support multiple communication links on a given frequency carrier shall maintain a frame-repetition rate with a frequency stability of at least 10 ppm.	6.2.2
Jitter	15.323(e).4 The jitter (time-related, abrupt, spurious variations in the duration of the frame interval) introduced at the two ends of such a communication link shall not exceed 25 μ s for any two consecutive transmissions.	6.2.3
Continuous transmit during frame	15.323(e).5 Transmissions shall be continuous in every time and spectrum window during the frame period defined for the device.	6.2.3
Carrier stability	15.323(f)	
Carrier frequency stability (< 10 ppm)	15.323(f).1 The frequency stability of the carrier frequency of the intentional radiator shall be maintained within ± 10 ppm over 1 hour or over the interval between channel access monitoring, whichever is shorter.	6.2.1.1
Carrier frequency stability (extreme conditions)	15.323(f).2 The frequency stability shall be maintained over a temperature variation of -20 $^{\circ}$ C to $+50$ $^{\circ}$ C at normal supply voltage, and over a variation in the primary supply voltage of 85 percent to 115 percent of the rated supply voltage at a temperature of 20 $^{\circ}$ C.	6.2.1.3
Carrier frequency stability (battery)	15.323(f).3 For equipment that is capable only of operating from a battery, the frequency stability tests shall be performed using a new battery without any further requirement to vary supply voltage.	6.2.1.2

Annex B

(informative)

Radiated and conducted measurement of power output and monitoring thresholds

This appendix contains background material to support the procedures in Clause 4 of this standard.

B.1 General

To measure relative values of the electromagnetic compatibility (EMC) and operational compatibility (OC) test signals, or to sample the signal for further relative analysis, measurements can be performed at noncalibrated test facilities.

B.1.1 Detachable antennas

If sample EUTs can be tested with connections provided by the manufacturer in place of antennas or if the EUT has detachable antenna(s),³² then conducted measurements are preferred. Conducted measurements do not require a facility that complies with the requirements of ANSI C63.4-2003. In addition to the conducted measurements of emissions power and monitoring threshold, radiated tests of the EUT transmit antenna gain and the EUT transmit and monitoring system coverage equivalency may be necessary. If so, the EUT antenna-related parameters should be tested as recommended by IEEE Std 149-1979, or equivalent documents. As a rule, the radiated measurements must be performed at a test facility that meets the free-space requirements as set forth in Clause 6. To measure absolute values of conducted test signals, noncalibrated signals can be used. To measure absolute values of radiated signals, calibrated test facilities must be used.

B.1.2 Nondetachable antennas

Radiated measurements of the EMC and OC characteristics must be performed on equipment with nondetachable antennas even when the EMC and OC performance limits are specified in terms of conducted units, if sample EUTs cannot be tested with connections provided by the manufacturer in place of antennas. In this case, the radiated test results obtained must be correlated with specified conducted limits. When necessary, the EUT antenna-related parameters should be tested as recommended by IEEE Std 149-1979, or equivalent documents. As a rule, the radiated measurements must be performed at a test facility that meets the free-space requirements as set forth in Clause 4.

B.1.3 Alternative test facilities, measurement techniques, and test site validation

The preferred radiated test environment is free space. In a simulated free-space environment, there are no requirements for the ground plane of the facility. Alternative test environments and techniques are also permitted, provided their correlation with the preferred methods can be demonstrated. If the test methods are not given in this standard, the procedures recommended by ANSI C63.4-2003 and other applicable standards shall be used. When TEM cell-based test facilities are used (e.g., a wideband TEM cell), the measured quantity is not field strength but rather radiated power. In this case, the computation of radiated parameters must be performed according to the facility manufacturer's instructions and correlated with free-space measurements. Test site validation documentation must be provided in the test report, demonstrating the required ratio of direct and reflected signal components for approximating the free-space environment or correlation with recommended methods for alternative techniques (e.g., a wideband TEM cell).

³² Detachable antenna(s), if provided as a standard configuration, shall be in conformance with the requirements of 47CFR15.203.

B.2 Power limits

B.2.1 Transmit power limits

For EUTs with antenna gain less than a certain value g , which is specified in the applicable regulations,³³ the maximum EUT transmit power at the transmit antenna terminals is $P_{\max} = 10^{-4} \sqrt{B}$ W, where B is the EUT emission bandwidth in hertz. In decibels referenced to 1 mW, $P_{\max} = 5 \log B - 10$. If the antenna gain exceeds g , then the actual EUT transmit power P_{EUT} must be reduced below this limit by the amount that the directive gain of the EUT transmit antenna (relative to an isotropic antenna) exceeds a certain value g , as shown in the following equation:

$$P_{\text{EUT}} \leq P_{\text{limit}} \text{ where } P_{\text{limit}} = \begin{cases} P_{\max} - (G_A - g), & \text{when } G_A > g \\ P_{\max}, & \text{when } G_A \leq g \end{cases} \quad (\text{B.1})$$

where

G_A is the maximum directional gain of the EUT transmit antenna

B.2.2 Monitoring threshold limits

The maximum monitoring threshold for an EUT transmitting the maximum allowed power is M_L dB or M_U dB above kT_0B , where $k = 1.38 \times 10^{-23}$ W/K Hz, (Boltzmann's constant), $T_0 = 290$ K (a defined absolute temperature), and B is the measured emissions bandwidth (in hertz). The selection of M_L or M_U is made based on whether the EUT implements the LIC algorithm and how many channels a system built with the EUT realizes. If the EUT does not implement the LIC algorithm or if a system built with the EUT realizes less than 40 channels, then the selection is limited to M_L ; otherwise, M_L or M_U may be selected at the manufacturer's discretion.

For an EUT transmitting less than the maximum permitted power, the monitoring threshold limit increases by the difference between P_{limit} and P_{EUT} . The effect of the rules, therefore, is to place an upper bound on the sum of the EUT transmit power and monitoring threshold.

A provision is made in the EUT test procedures for an uncertainty margin U_M . This margin is provided to account for the effects of measurement noise in the EUT's operations, the intent being to allow the manufacturer to implement EUTs with the thresholds as defined without having to incrementally reduce the implemented threshold so as to allow for statistical variation in measurement results and other sources of measurement error.

B.2.3 EIRP and electric field (E-field) threshold limits for radiated tests

For an EUT with a nondetachable antenna and without a test connector added to the EUT for the purposes of evaluation, the transmit power must be measured in terms of EIRP referenced to an equivalent conducted level according to the calibration of the radiated test facility.

Measurement of the monitoring thresholds must be based on an equivalent E-field incident on the transmit antenna, generated according to the calibration of the radiated test facility, or using the path loss method of 4.4.

³³ 47CFR15.319(e) specifies $g = 3$ dBi.

B.2.4 Separate transmit and monitoring antennas

The EUT monitoring antenna shall provide coverage, equivalent to the EUT transmit antenna, that may result in further correction to the monitoring threshold. The following definition of equivalent coverage is adopted.

The monitoring system shall cause deferral to any transmission of sufficient strength to induce a power level in the EUT transmit antenna that exceeds the maximum threshold allowed for the system under test, measured at the transmit antenna input.

In applying this principle to develop tests for equivalent coverage, the following assumptions are made:

- a) Distance between the transmit and monitoring antennas is not specified in the rules and therefore is determined by the system designer.
- b) There is no requirement that the gain and pattern characteristics of the transmit and monitoring antennas be identical.
- c) Reciprocity exists between transmit and receive gain and pattern characteristics of the transmit antenna, and the transmit antenna is essentially a lossless radiator.

To verify that the monitoring antenna has coverage equivalent to that of the transmitting antenna, it is necessary to demonstrate that the EUT defers if a received signal is sufficiently strong to generate an at-threshold power level at the transmit antenna terminals, unless the transmit and receive antennas are substantially identical and are collocated.

B.3 Transmit power and monitoring threshold test method selection

Practical procedures to demonstrate compliance with the transmit power and monitoring threshold limits depend on the availability of the antenna terminals for measurements and the relationship between the transmit and monitoring antennas.

B.3.1 Detachable transmit and monitoring antennas

If a single antenna performs both transmission and monitoring functions, or the transmit and monitoring antennas are separate but identical and collocated, the equivalent coverage requirements are always met. In this case, when the EUT antenna is detachable or can be replaced by a connector (and matching circuit, if necessary), testing to demonstrate compliance with the output power and threshold limits requires determination of the antenna gain in the direction of maximum radiation, and conducted measurements of the EUT transmit power and monitoring threshold at the antenna terminals. The antenna gain in the direction of maximum radiation is determined from typical antenna measurements or manufacturer's declaration. It may be possible to measure the EUT gain in facilities that measure radiated power, such as a wideband TEM cell. In this case, the correlation should be demonstrated with free-space antenna measurements. Detailed threshold measurements are described in Clause 7.

When the EUT transmit and monitoring antennas are detachable, but different and collocated, the threshold limit must also account for the equivalent transmit/monitoring antenna coverage. The coverage measurements can be performed with a reference antenna illuminating the EUT transmit and monitoring antennas, maintaining a controlled receive power level at the EUT transmit antenna terminals; the level at the monitor antenna is uncontrolled but the implemented threshold must be chosen by the manufacturer to cause deferral for all levels for which the level at the transmit antenna is above the appropriate margined threshold. The test is done with horizontally and vertically polarized reference antennas for a limited number of EUT orientations. Corresponding procedures can be devised when the tests are made at radiated power-measuring facilities (e.g., a wideband TEM cell).

If the transmit and monitoring antennas can be separated from each other by a maximum distance s , it is suggested that the power T_M at the EUT transmit antenna terminals be established only for one point at distance r between the reference antenna and the EUT in the direction of EUT transmit antenna maximum radiation, by applying corresponding power P_{Ref} at the terminals of a reference antenna. Then, while the position of the reference antenna is not changed, the monitoring antenna is placed at a distance $r + s$ from the reference antenna, and is positioned in multiple orientations. If the EUT fails to defer in any orientation, the reference antenna should be rotated 90° about the direction to the EUT. Only if the EUT again fails to defer should it be held noncompliant.

B.3.2 Nondetachable transmit and monitoring antennas

When access to the EUT antenna terminals is not available [antennas are nondetachable and no provisions have been made in the test samples for a matched connection made in place of the antenna(s)], only radiated measurements are possible, and tests for compliance with the rules must be based on measurements of EIRP and the response of the EUT to the applied field strength. Procedures to determine the gain G_A of detachable antennas based on power comparison at the antenna terminals are not applicable. Several alternative test techniques are possible based on measurements of radiated field intensities and/or antenna-related parameters. The relationships given in B.3.3 allow the EIRP and the applied field strength threshold to be determined in the free-space environment with a reference antenna, which is first used to measure the radiated field strength from the EUT and then used to generate a field incident at the EUT.

B.3.3 Relationships for radiated measurement of EIRP

In a free-space environment, the radiated field intensity is related to the transmitted power at the antenna terminals, shown in the following equation:

$$E(\theta, \phi) = \frac{1}{r} \sqrt{30PG(\theta, \phi)} \quad \text{V/m} \quad (\text{B.2})$$

where

- P is the power (in watts) applied to the EUT antenna terminals
- r is the distance in meters from the antenna to the observation point
- $G(\theta, \phi)$ is the directive gain of the transmit antenna in the (θ, ϕ) direction.

Converting to logarithmic units and considering the direction (θ, ϕ) in which the EUT antenna gain achieves its maximum value G_A , given in the following equation:

$$E_{\text{EUT,max}} = P_{\text{EUT}} + G_A - 20 \log_{10} r + 104.8, \quad \text{dB}\mu\text{V/m} \quad (\text{B.3})$$

$$\text{EIRP}_{\text{EUT}} = P_{\text{EUT}} + G_A \quad (\text{B.4})$$

where

- G_A (dBi) is the maximum directive antenna gain of the EUT
- P_{EUT} is in dBm

From Equation (B.3) and Equation (B.4), the EIRP is related to the measured field by the following equation:

$$\text{EIRP}_{\text{EUT}} = E_{\text{EUT,max}} + 20 \log_{10} r - 104.8. \quad (\text{B.5})$$

B.4 General guidelines on measurement conditions and procedures

B.4.1 Conducted measurements

When the transmit and monitoring system power can be measured at the EUT antenna terminals, these characteristics are tested with conducted measurements, and the procedures described in Clause 7 can be applied directly. Only the transmit antenna gain and the transmit and monitoring system equivalent reception tests must be performed using radiated measurements.

The EUT transmit antenna gain is determined as recommended in IEEE Std 149-1979. For WB TEMs, the test procedure is similar with the EUT being rotated within the cell. However, the measured quantity is not field strength but rather radiated power.

B.4.2 Radiated measurements

Since the measurement parameters and variables can be expressed in several different, albeit equivalent, ways, a number of test procedures can be used to evaluate the EUT with nondetachable antennas. As an example, some of the methods presented in the standard test procedures are based on radiated propagation (see Figure 2 and 4.8). Corresponding test procedures can also be based on facilities that measure radiated power (wideband TEM, etc.), where instead of using the reference antenna, the necessary power levels are generated and/or measured by the test facility itself.

The preferred test environment for radiated measurements is “free space.” For purposes of the tests specified in this standard, the free-space environment can be realized in a wideband TEM, an anechoic chamber, or simulated at an open-area test site (OATS) or semi-anechoic chamber by maintaining at least 10 dB loss of the signal reflected from the ground plane to the line-of-sight signal. A simulated free-space environment can be achieved, for example, by lining the OATS or semi-anechoic chamber ground plane with an RF absorber, by using the elevated test sites where both the EUT and the test antennas are placed at a sufficient distance (height) over the ground plane and other reflective objects, and by utilizing directive reference antennas, which reject the reflected wave to a sufficient degree.

In a simulated free-space environment, there are no specific requirements for the ground plane of the facility. The free space and simulated free-space environment site validation documentation must be provided, which demonstrates the required ratio of direct and reflected signal during the test.

To measure the EUT gain at facilities that make field strength measurements, install the EUT at a nonconducting table or a turntable at the test site. Attach the EUT transmit antenna(s). Install a linearly polarized calibrated reference at a distance $r_t > 2D^2/\lambda$ from the EUT, where D is the largest dimension of the EUT and λ is the wavelength of the signal. Align the reference antenna for its major lobe facing the EUT. Configure the reference antenna as a receive antenna. Find the EUT direction of maximum radiation by measuring the EUT emissions at sufficient number of equally spaced points on the surface of a sphere with radius r and the EUT transmit antenna at its center. This can be achieved, for example, by measuring the E-field intensity with horizontally and vertically polarized reference antenna, while moving the EUT within 0° to 360° azimuth and 0° to 180° elevation plane angle variations. After the direction of the EUT maximum radiation is found, the EUT gain G_A can be determined using standard procedures for antennas.

For facilities that measure radiated power, such as WB TEMs, install the EUT in the center of the test volume using nonconductive material to position the unit. Find the EUT direction of maximum radiation by measuring the EUT emissions at sufficient number of equally spaced points on the surface of a sphere surrounding the EUT. After the direction of the EUT maximum radiation is found, the EUT gain G_A can be determined using standard test procedures for antennas.

Annex C

(informative)

Options for implementing the tests of Clause 7 and Clause 8

This annex discusses recommendations for the multicarrier interference generator that may be used to block use of particular carriers and timeslots as required by tests of Clause 7 and Clause 8. An example implementation is provided of one such multicarrier interference generator.

While the tests described in this standard are based on general-purpose instrumentation, tests using alternative, more specialized instrumentation can, in some cases, be performed more quickly with equally valid results. For some EUTs (e.g., those operating in conformance with an industry standard air interface), instruments may be available that are specifically designed to test equipment using a particular type of modulation, frequency channelization, frame structure, etc. Those instruments may be capable of automatically performing some of the tests specified in Clause 6 (e.g., emission bandwidth, PSD). Such instruments can be used instead of general purpose instruments (spectrum analyzers, signal analyzers, etc.).

C.1 Multicarrier interference generator

A multicarrier interference generator capable of generating continuous wave (CW) signals on any selected combination of EUT carrier frequencies. Its exact specifications depend on the EUT, but may meet or exceed the following:

- Independently switchable (on/off) EUT carriers combined in a single 50 Ω RF output
- Power output per carrier ≥ -35 dBm
- Frequency tolerance $\leq 10\%$ of EUT center frequency separation
- Adjacent channel interference ≤ -30 dBc in EUT receiver noise bandwidth

The multicarrier interference generator may offer provisions for synchronizing with the slot timing of the EUT in order to provide timeslot-specific blocking.

C.2 General

The tests of Clause 7 and Clause 8 often require means by which specialized interference is applied to the EUT. For some tests, this interference must be synchronized with the frame and slot timing of the EUT. For example, 7.5 requires interference bursts of a particular length appearing at a particular location within the EUT's timeslots. Subclause 7.3.4 adds the requirement that the interference profile (the interference level on each carrier and timeslot) must be able to be changed in the frame prior to the initial transmit burst. These requirements create challenges for the test engineer.

These challenges can be addressed by means of a multi-triggerable multicarrier signal generator.³⁴ The generator is programmed to make carriers at a settable level on each of the RF carriers possible for the system. The carriers each are subdivided into timeslots whose level can be individually programmed. The generation of each frame by the vector signal generator is synchronized to the EUT timing by means of a frame-sync signal coming from either the EUT or the companion device, as appropriate, and applied to a trigger input for the vector signal generator. The switching from one interference profile to another is implemented by means of a second trigger to the vector signal generator whose source is a digital hardware flag generated by the controller in the EUT or companion device as appropriate, depending on the presence

³⁴ The example described here was implemented using a National Instruments PXI™-5670 RF vector signal generator.

of a user interface or other communications channel commencement means. This digital hardware flag is made active by the controller's software implementation during the setup of the communications channel during the frame previous to the first intended transmit frame of the communications channel.

C.2.1 The multicarrier signal generator

This implementation uses a general-purpose RF vector signal generator built within a card-based PXI™ mainframe.^{35, 36} The mainframe can incorporate a general-purpose Windows PC, and the generator elements consist of a programmable RF source with a wideband modulation port, and an arbitrary waveform generator. In this implementation, the functionality of the RF vector generator is under the control of a program running on the on-board PC.

The RF source element has attenuators and gain stages in provision for the setting of the overall signal level. The controlling software allows the test engineer to set the levels in individual timeslots. When the interference profile is loaded into the arbitrary waveform generator, drivers within the controlling software adjust the composite signal level so as to achieve the desired signal level for each of the carriers and timeslots.

The arbitrary waveform generator element generates an IF signal incorporating the desired multicarrier modulation, which is then applied to the RF source element. The arbitrary waveform generator is configured with two trigger inputs and two marker outputs. The triggers inputs are used to synchronize with the frame timing, and to change the interference profile immediately prior to the first transmit burst of a communications channel. The two marker outputs are used to show the timing of the interference profile change in the course of documenting the timed interference tests of the EUT.

C.2.1.1 Trigger functionality for the arbitrary waveform generator frame synchronization

The interference must be synchronized with the frame of the EUT so that time alignment with individual slots and timing within slots is controlled. In this implementation, the arbitrary waveform generator is programmed to make one frame of multicarrier signal, less a few microseconds. When the frame-sync signal arrives at the trigger, the arbitrary waveform generator generates one frame, then waits for the next trigger, which arrives in a few microseconds. Each timeslot is bracketed by idle periods, and the interval waiting for the next frame trigger occurs during the idle period following the last timeslot of the frame, so multicarrier signal integrity is preserved, yet small differences in the clock rates between the EUT and the test system are removed.

C.2.1.2 Trigger functionality for the arbitrary waveform generator on interference profile changes

The text of 7.3.4 requires that the interference profile be changed immediately prior to the first transmit burst of the communications channel. The arbitrary waveform generator's multiple-trigger capability is used to make the interference profile being generated change to a second profile on the receipt of a trigger signal. During test setup, the arbitrary waveform generator is loaded with both desired profiles, and each trigger event received by the arbitrary waveform generator causes it to switch to the other profile.

³⁵ This information is given for the convenience of users of this standard and does not constitute an endorsement by the IEEE of this product. Equivalent technology may be used if it can be shown to lead to the same results.

³⁶ PXI is a trademark of PXI Systems Alliance, Incorporated.

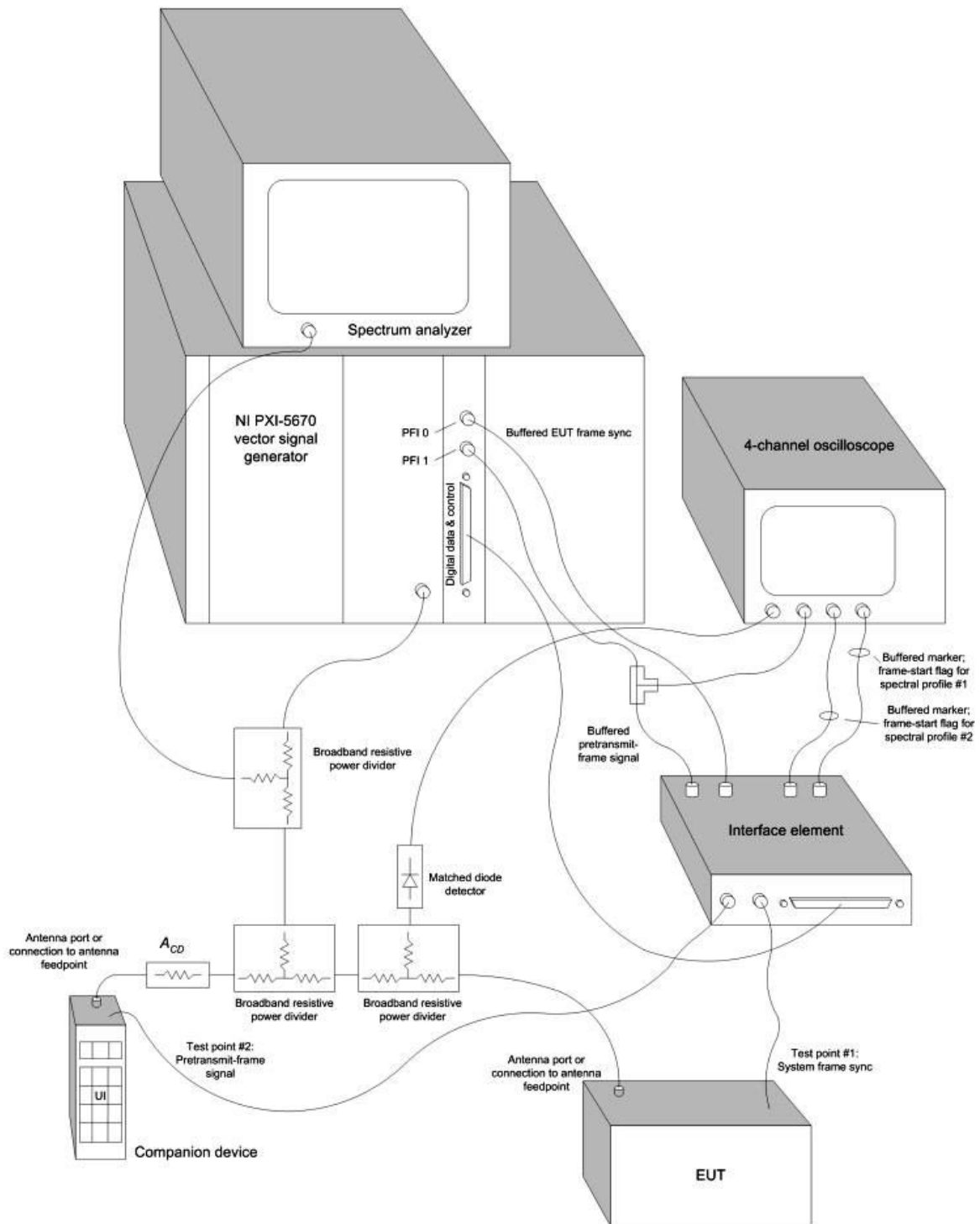

Figure C.1—An example implementation of a test system for the tests of Clause 7 and Clause 8

C.2.2 EUT and companion device provisions

The test system of this example requires that the EUT and the companion device provide the necessary trigger signals for the arbitrary waveform generator. In this example, the EUT and companion device form a cordless telephone system—a handset and a telephone base. The user interface is on the handset, and all communications channel initiation begins at the handset. The base provides a beacon to which the handset locks, and notifies the handset using a slow data channel on the beacon signal when the base has, for example, an incoming ringing signal. The base maintains system timing through the beacon, to which the handset synchronizes.

In this example, the base is always the source for the frame-sync signal, whether the base is the EUT and the handset is the companion device, or the handset is the EUT and the base is the companion device. The frame-sync signal is generated within the base by the hardware timing section, and is exactly synchronous with the start of the first slot of the frame.

In this example, the signal required to trigger the arbitrary waveform generator element of the RF vector signal generator is produced by the controller within the handset. The handset has the user interface, and when the user presses the TALK button to establish the communications channel, the handset establishes the communications channel to the base. The controller within the handset is timing-aware, and is configured to generate a single pulse on an otherwise unused digital I/O signal in the frame prior to the first transmit burst. This pulse is used to trigger the change of the interference profile generated by the arbitrary waveform generator. The functionality of the pulse and the trigger is independent of whether the handset is the EUT and the base is the companion device, or the base is the EUT and the handset is the companion device.

C.2.3 Interface element

The RF vector signal generator trigger inputs are assumed to be general-purpose digital inputs with a reasonably low input impedance. It is necessary to buffer the frame-sync and pretransmit-frame signals, rather than routing them directly from the EUT and companion device to the RF vector signal generator trigger inputs. In addition, the timing markers generated by the RF vector signal generator on the digital data and control port of the arbitrary waveform generator are very short duration pulses; if these pulses were displayed on a four-channel digital oscilloscope with sufficient span to see multiple frames, and thus to show the deferral or initiation of a transmit pulse at the moment of an interference profile change, the pulses would be too short to be captured.

These problems are addressed using a multipurpose interface element between the vector signal generator and the rest of the system. On the trigger lines, buffering is provided within the interface element using CMOS logic that can drive trigger inputs. Displayable marker signals are generated using the interface element by means of ICM7555 or similar short-pulse-triggerable one-shot devices. The ICM7555 also facilitates the conversion to CMOS levels of the LVDS-level differential signals of the marker signals coming from the digital data and control port of the arbitrary waveform generator. The port on the arbitrary waveform generator is a 68-pin male VHDCI and the construction of the interface element is facilitated by using a similar connector. Cable assemblies are commercially available.

C.2.4 Software

LabVIEW™ software³⁷ used in the example is publicly available on the web, in the National Instruments developer's zone area.³⁸ Search on UPCS from the search window in <http://www.ni.com>. The software is provided in the public interest to assist in the understanding of this example and these means by which the tests of Clause 7 and Clause 8 may be implemented. The use and configuration of the software is the responsibility of the user.

³⁷ LabVIEW is a trademark of National Instruments, Incorporated.

³⁸ This information is given for the convenience of users of this standard and does not constitute an endorsement by the IEEE of this product. Equivalent technology may be used if it can be shown to lead to the same results.

C.3 Alternative approaches

The example discussed in this subclause assumes that trigger signals are available from the EUT and companion device. Without these trigger signals, synchronization and timing are difficult.

It might be possible to use the example multicarrier interference source triggered by the detection of the beacon as a timing signal; which absolute timeslot was in use would not be known, but timeslot blocking would be possible in a relative sense.

It might be possible to use a signal captured from the EUT or companion device's user interface (as opposed to the example that uses a flag generated by the EUT or companion device's controlling software) to trigger the transition from one interference profile to another, if a compensatory delay were inserted in the trigger so as to correspond to the delay in the UI in processing the action.